

# SOLARPANELMOUNTINGSTRUCTURES

---

**TINROOF**

**RS.3PERWATT(1to5KW)RS.2  
.5PERWATT(10KW)**

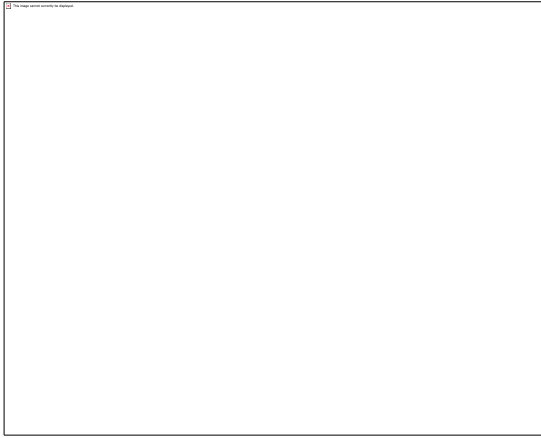
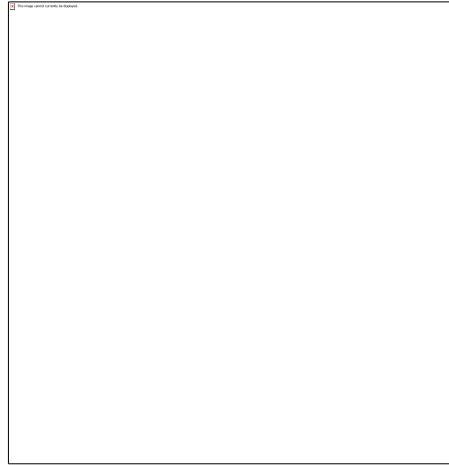

**RCCROOFTOP-ALUMINIUM**

**RS.5PERWATT(1TO5KW)RS.  
4.5PERWATT(10KW)**

**RCCROOFTOP-GI**

**RS.4.5PERWATT(1TO5KW)RS.  
4PERWATT(10KW)**

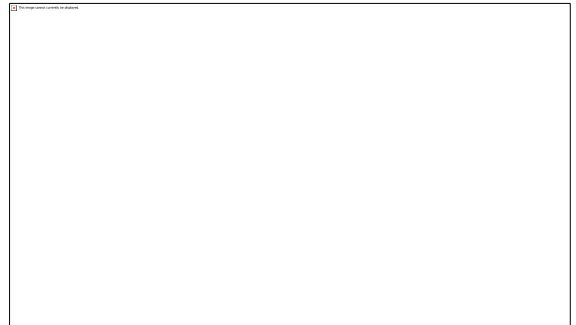

**30mm60mm100mmMICROCHANNELS**



**RS.1.5PERWATT**

# COMPONENTS

**ALUMINIUM STRUT CHANNELS 4**  
**1X41MM THICKNESS 2.4MM**  
**LENGTHS 2.15mtrs and 1.6mtrs**

**ALUMINIUM LEGS 1.8mtrs**

**SPRING NUTS**

**CHANNEL JOINT**  
**BLOCK SPVC**

**C-**  
**CHANNEL JOINT**  
**ALUMINIUM**

**MID**  
**CLAMP SHEIG**  
**HT 30MM**  
**WIDTH 20MM**

**MID**  
**CLAMP SHEIG**  
**HT 35MM**  
**WIDTH 30MM**

**MID**  
**CLAMP SHEIGHT 9M**  
**M**  
**WIDTH 20MM**

**ALLEN CAP  
BOLTS30MM60MM10  
0MM**



**END  
CLAMPSHEIG  
HT37MM**

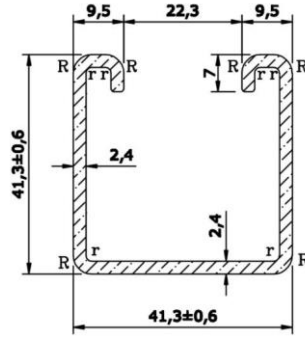

**ANCHORBOLTS  
45MM75MM**

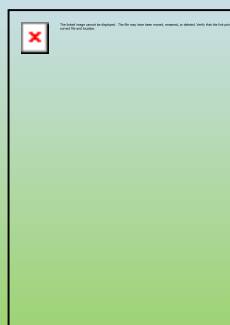
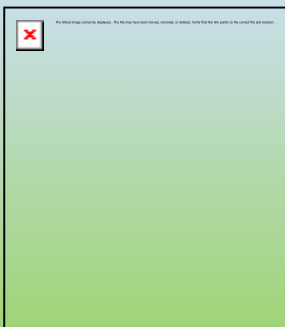
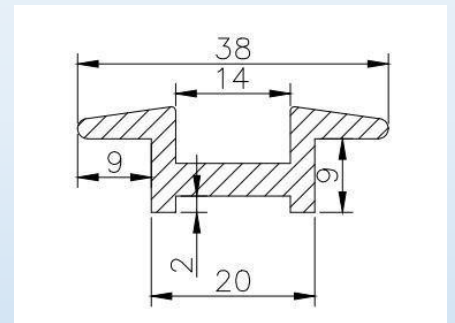
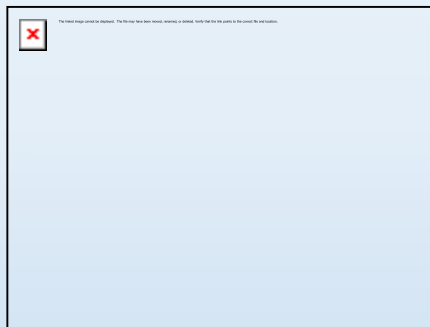
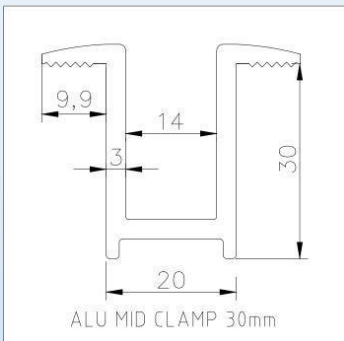
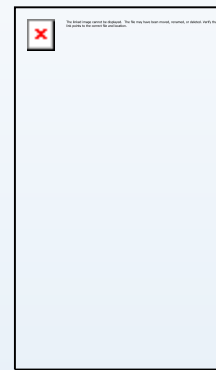
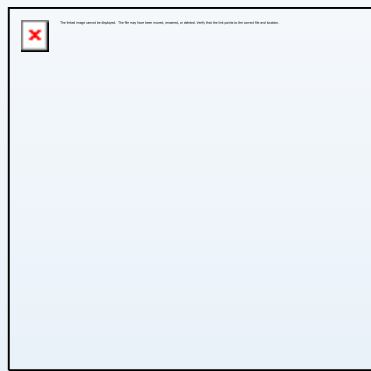
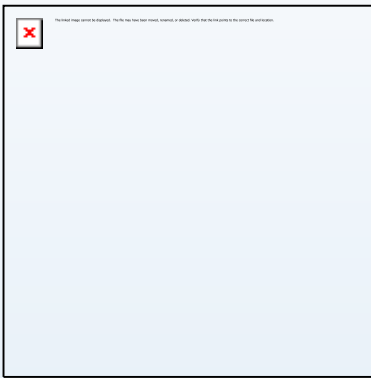
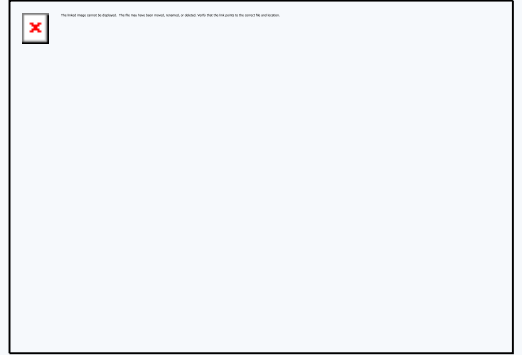

# COMPONENTS

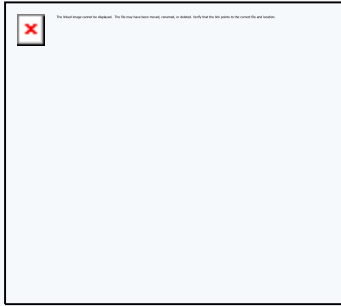

**MICROCHANNELS**  
30mmx350mm

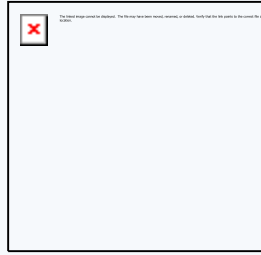

**MICROCHANNELS**  
60mmx350mm



**MICROCHANNELS**  
100mmx350mm

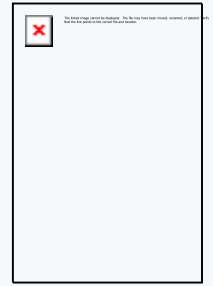

**MICROCHANNELSNUT**  
60mm100mmONLY

# RCCLEGGCOMPONENTS



**BASEPLATEHDG**  
150X75mm

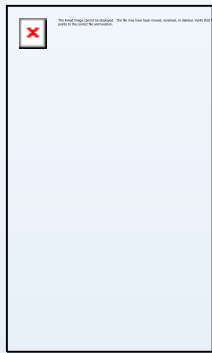

**ALUCBRACKET**  
150X45mm

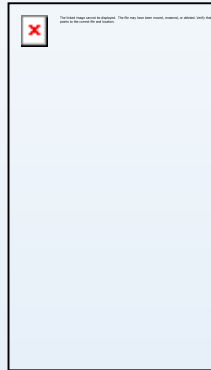

**BACK SIDE**  
**LEG400MMHEIG**  
**HT**

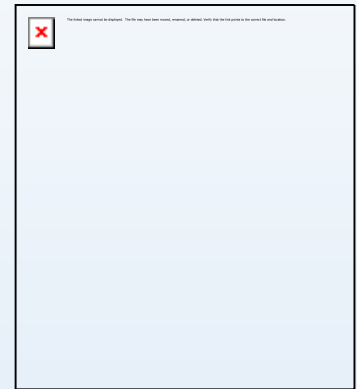

**ELEVATEDLEGS**  
1MTR2MTR3MTR





# STRUCTURE COSTS SINGLE ROW

## 1 ROW

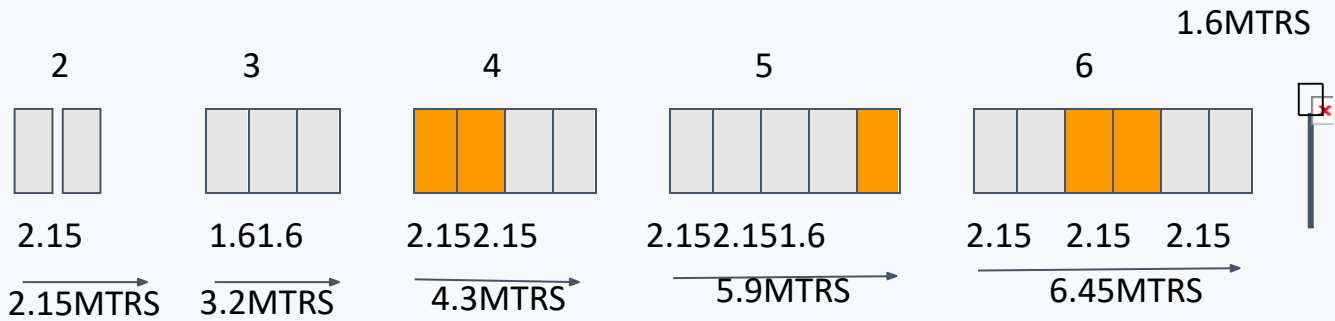

	PANEL STRCUTRE PRICE		sept 2020
NO PANELS	RCC PRICE ( MODEL 1600 LEG )	TIN PRICE	MICRO PRICE
1	3000	900	650
2	3000	1200	1000
3	5000	2000	1300
4	5500	2500	1700
5	7400	3500	2000
6	7800	4000	2300
7	9700	4800	2800
8	10000	5000	3000
9	12000	6000	3400
10	12300	6500	3800
15	18000	9800	5500
20	24000	12500	7000
30	35000	19000	11000
	GST 18% EXTRA		
	TRANSPORT EXTRA		
CUSTOM DESIGN LEGS ARE AT EXTRA COSTS			
ELEVATED MODELS WILL HAVE MORE LEG SETS			

# STRUCTUREBOM

## RCCROOFSIGNLEROWMODEL1600

NO OF PANELS	LEGS	ANCHOR BOLTS	2.15 CHANNEL	1.6 CHANNEL	MID CLAMP	END CLAMP	RCC SPRING NUTS	RCC ALLEN CAP
0	0	0	0	0	0	0	0	0
1	2	8	0	2	0	4	4	4
2	2	8	2	0	2	4	6	6
3	3	12	0	4	4	4	16	16
4	3	12	4	0	6	4	18	18
5	4	16	4	2	8	4	24	24
6	4	16	6	0	10	4	26	26
7	5	20	6	2	12	4	32	32
8	5	20	8	0	14	4	34	34
9	6	24	8	2	16	4	40	40
10	6	24	10	0	18	4	42	42
20	11	44	20	0	38	4	82	82
30	16	64	30	0	58	4	122	122
22	12	48	22	0	42	4	90	90
15	9	36	14	2	28	4	64	64



## TINROOFSTRUCTURESINGLEROWFULLRAIL

NO OF PANELS	2.15 CHANNEL	1.6 CHANNEL	MID CLAMP	END CLAMP	TIN SPRING NUTS	TIN ALLEN CAP	PVC CONNECT BLOCK
0	0	0	0	0	0	0	0
1	0	2	0	4	4	4	0
2	2	0	2	4	6	6	0
3	0	4	4	4	8	8	2
4	4	0	6	4	10	10	2
5	4	2	8	4	12	12	4
6	6	0	10	4	14	14	4
7	6	2	12	4	16	16	6
8	8	0	14	4	18	18	6
9	8	2	16	4	20	20	8
10	10	0	18	4	22	22	8
20	20	0	38	4	42	42	18
30	30	0	58	4	62	62	28
22	22	0	42	4	46	46	20
15	14	2	28	4	32	32	12

# STRUCTUREBOM

## TINROOFMICRORAIL30MMSINGLEROW

NO OF PANELS	MID CLAMP	END CLAMP	TIN SPRING NUTS	TIN ALLEN CAP	MICRO CHANNEL 30 MM
0	0	0	0	0	0
1	0	4	4	4	4
2	2	4	6	6	6
3	4	4	8	8	8
4	6	4	10	10	10
5	8	4	12	12	12
6	10	4	14	14	14
7	12	4	16	16	16
8	14	4	18	18	18
9	16	4	20	20	20
10	18	4	22	22	22
20	38	4	42	42	42
30	58	4	62	62	62
22	42	4	46	46	46
15	28	4	32	32	32





# RCCSTRUCTURE



The image cannot be displayed. The file may have been moved, renamed, or deleted. Verify that the path points to the correct file and location.



The image cannot be displayed. The file may have been moved, renamed, or deleted. Verify that the path points to the correct file and location.

# RCCSTRUCTURE

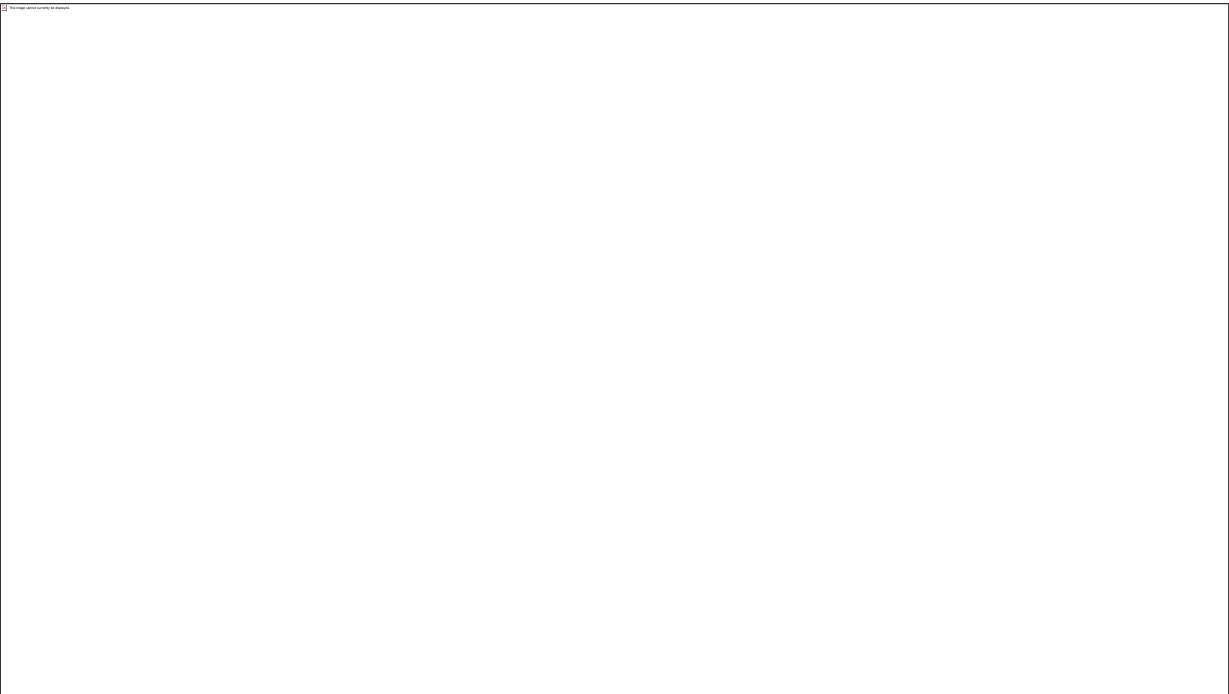

# RCCSTRUCTURE

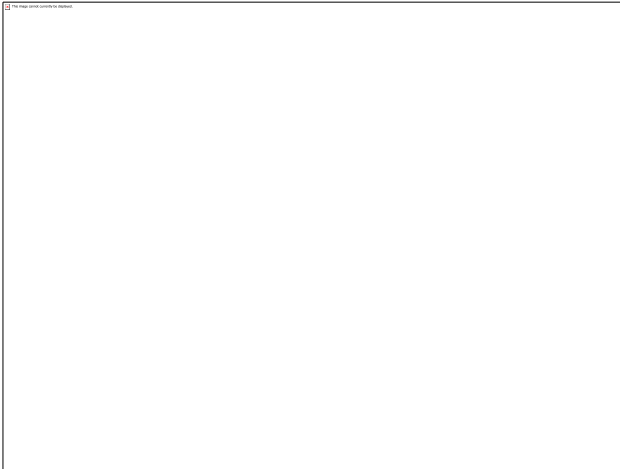
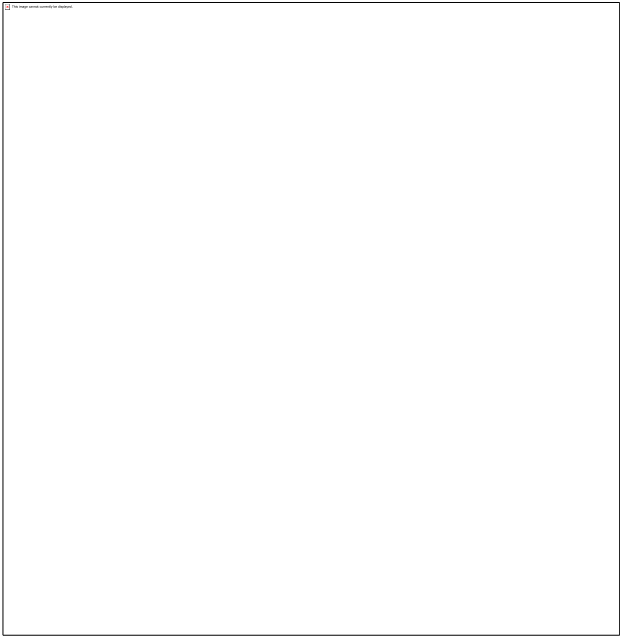
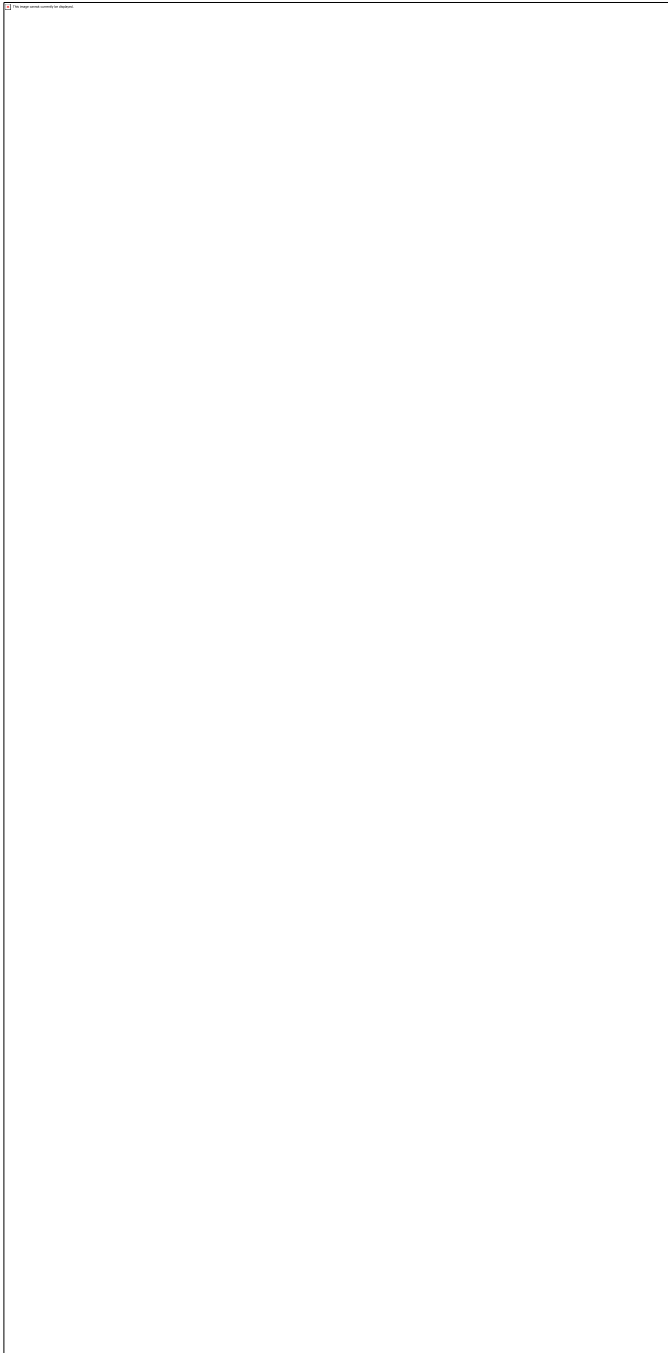

# TINROOF

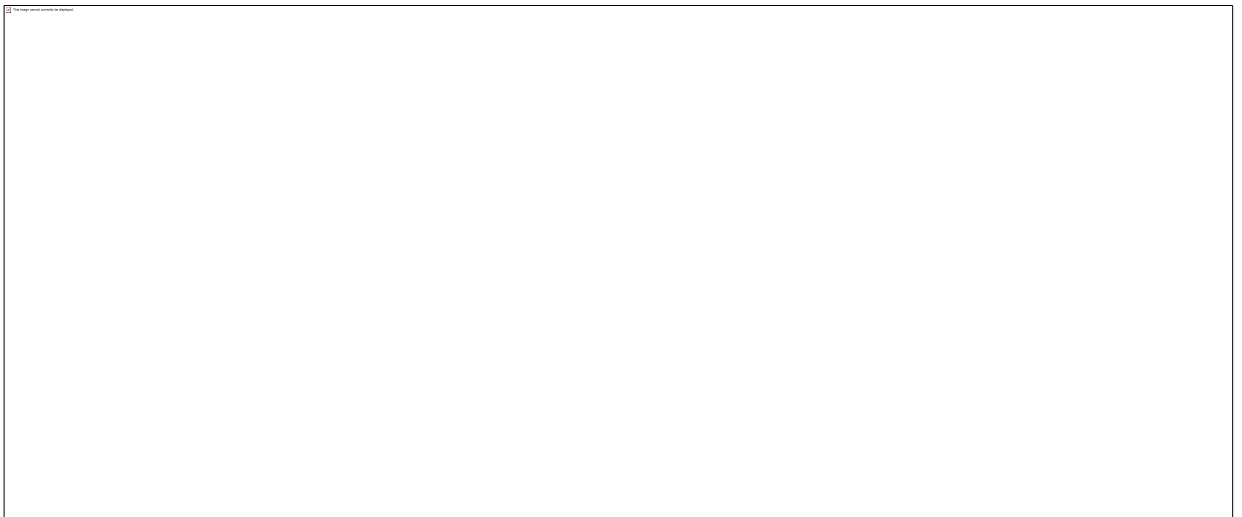
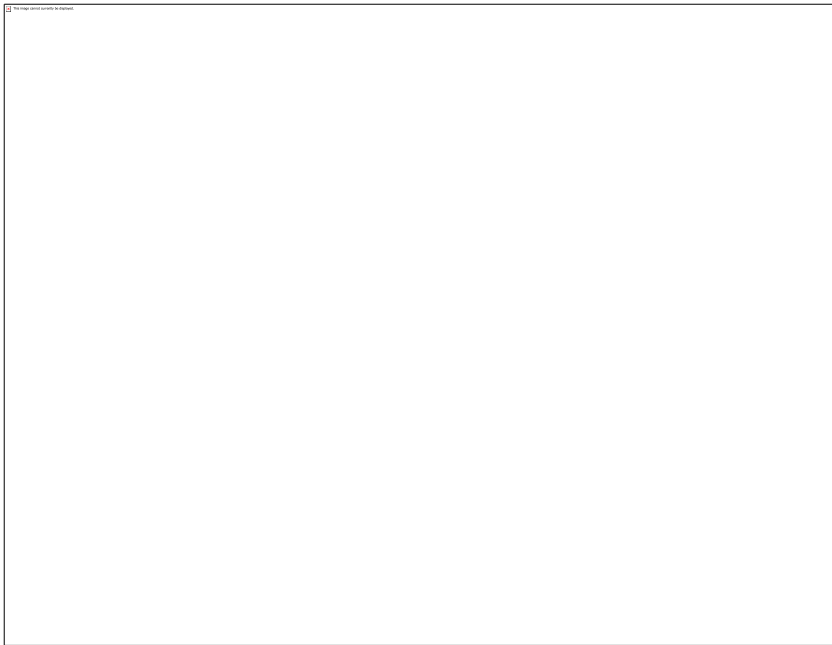
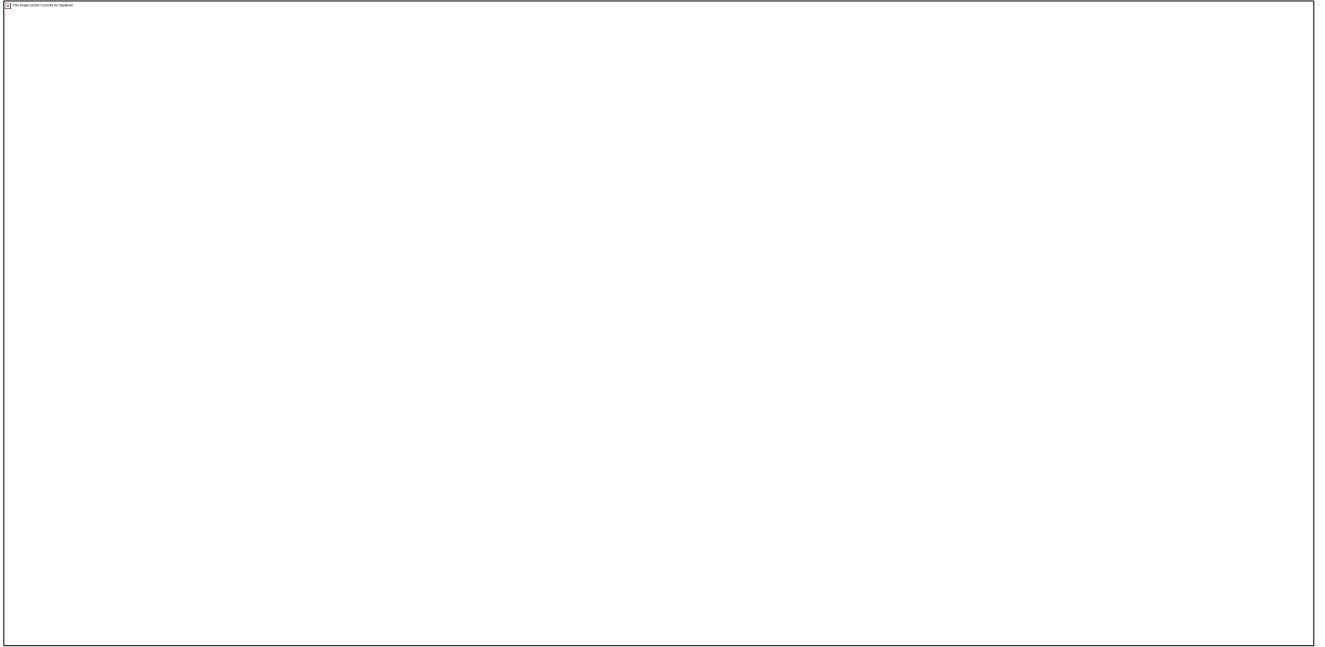

# MICROCHANNEL

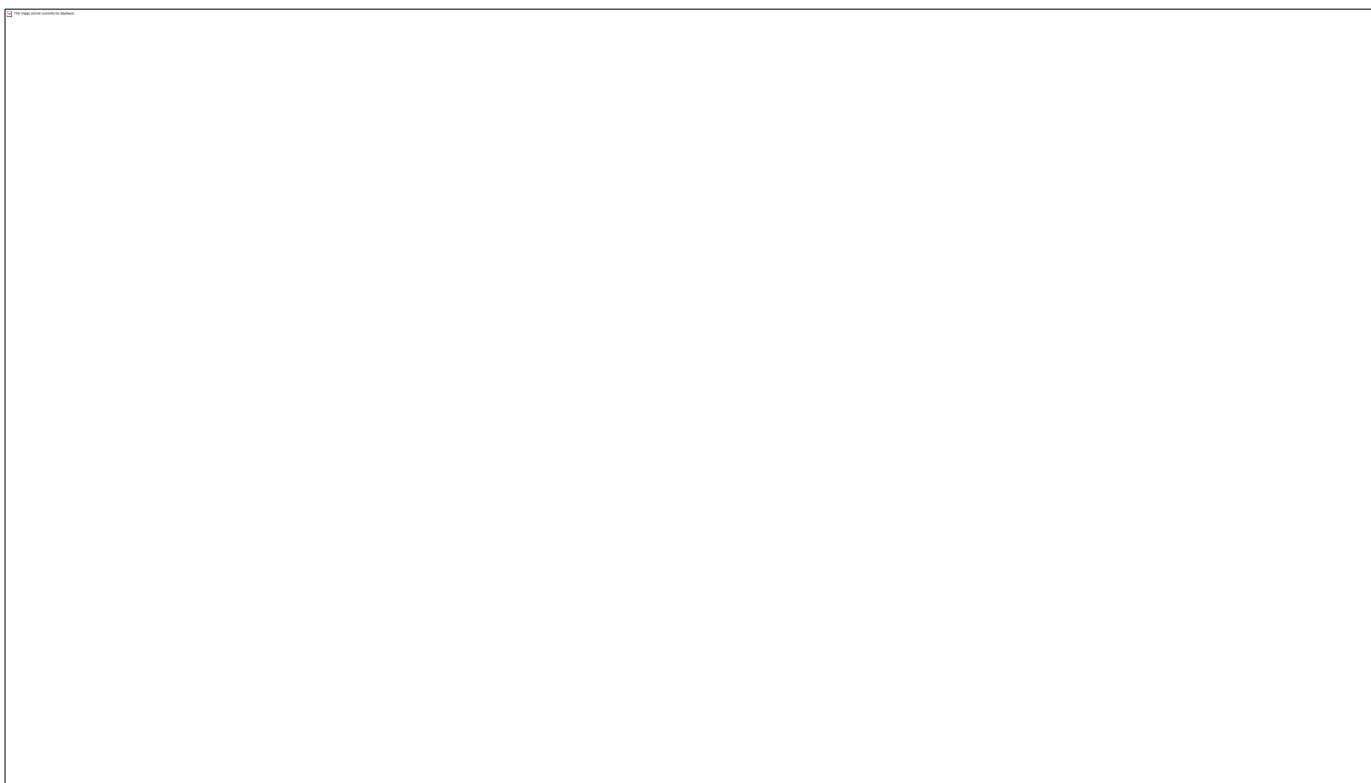
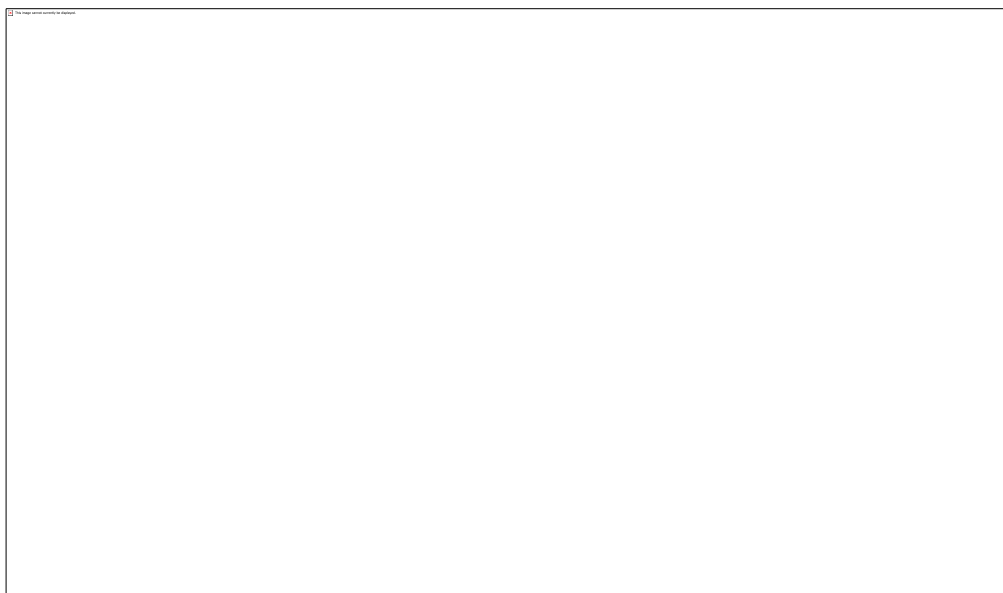
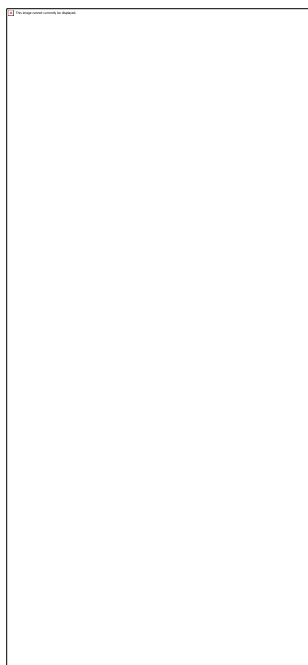

# ELEVATED ROOF

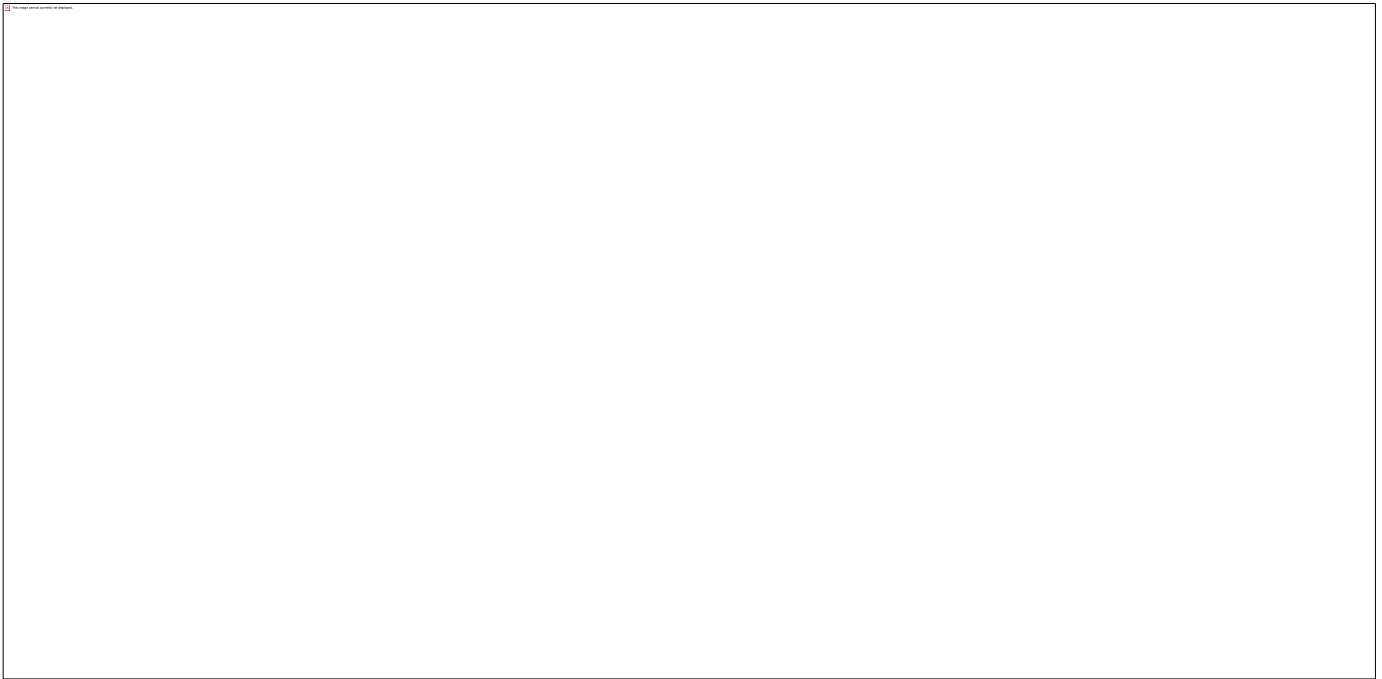

# PANEL CONFIGURATIONS RCC ROOF 6

## 0 CELLS 1690X990mm

### 1 ROW

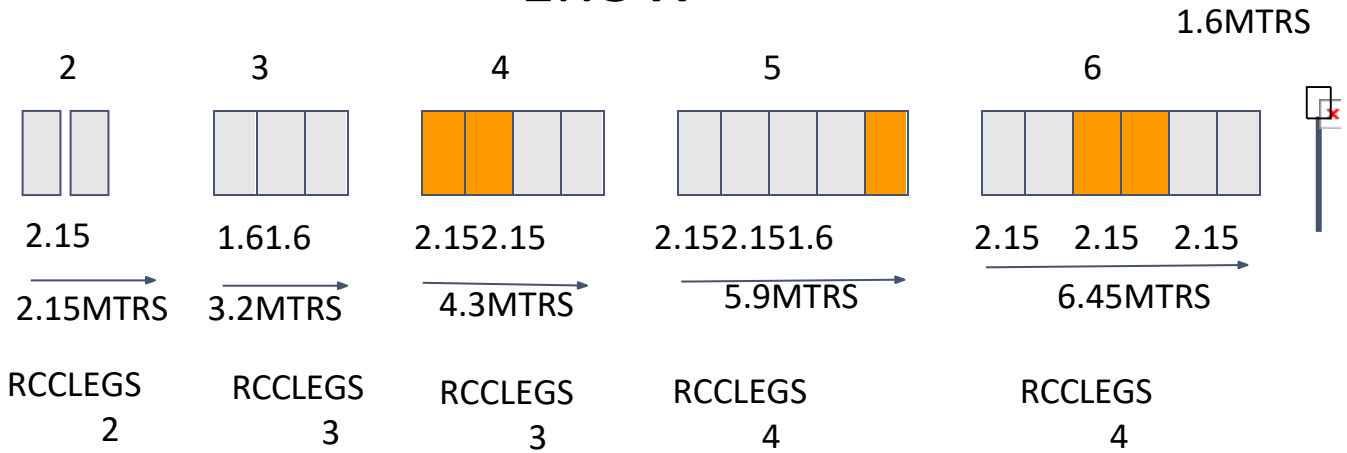

### 2 ROWS

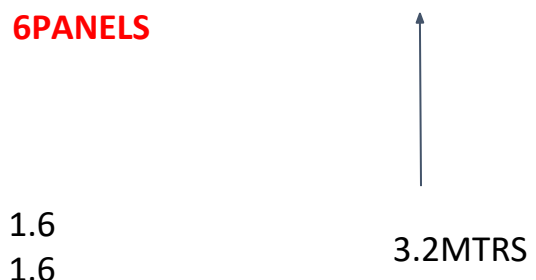
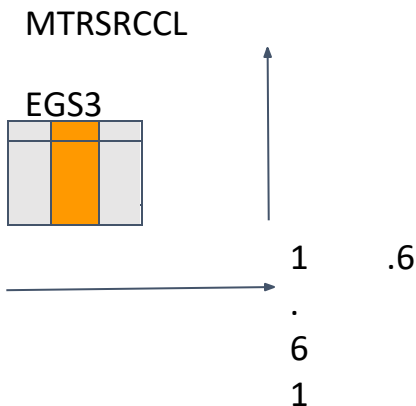
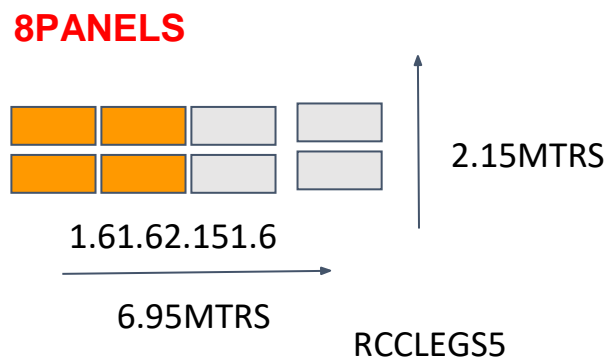
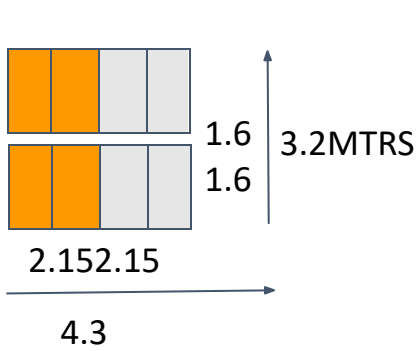
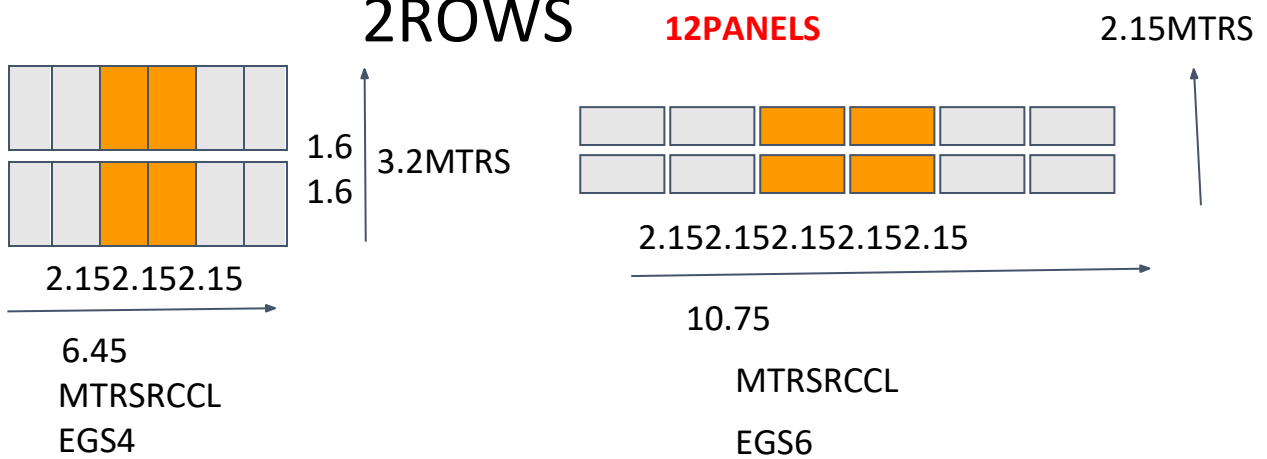

1.61.6

2.15

5.

3

5

M

T

R

S

3.2MTRS

2

.

1

5

M

T

R

S

RCCLEGS3

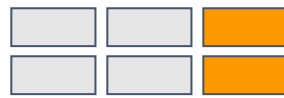

RCCLEGS4





# PANEL CONFIGURATIONS RCC ROOF 7

## 2 CELLS 1960 X 990 mm

### 1 ROW

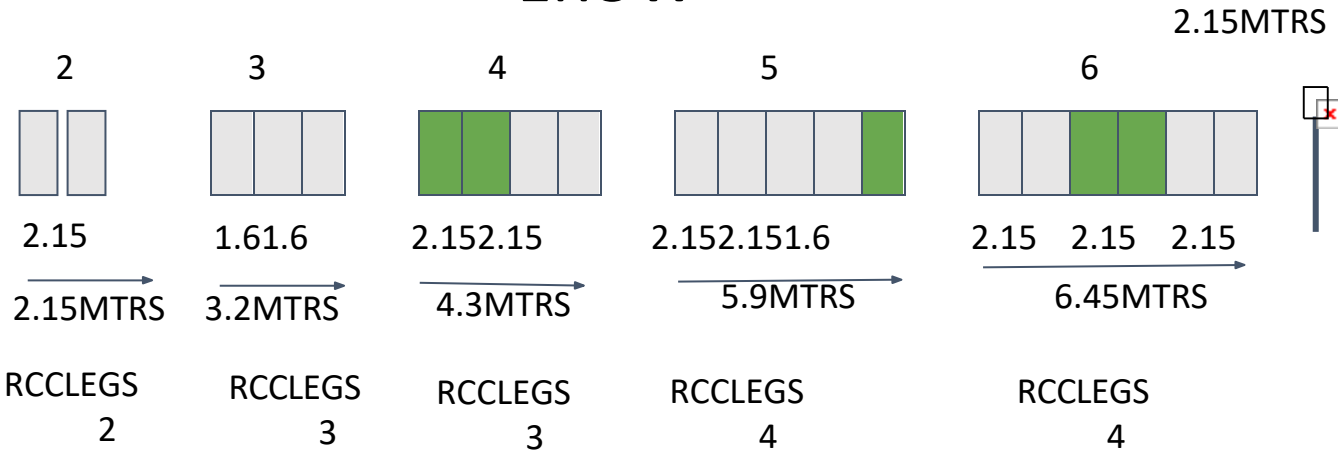

### 2 ROWS

**12 PANELS**

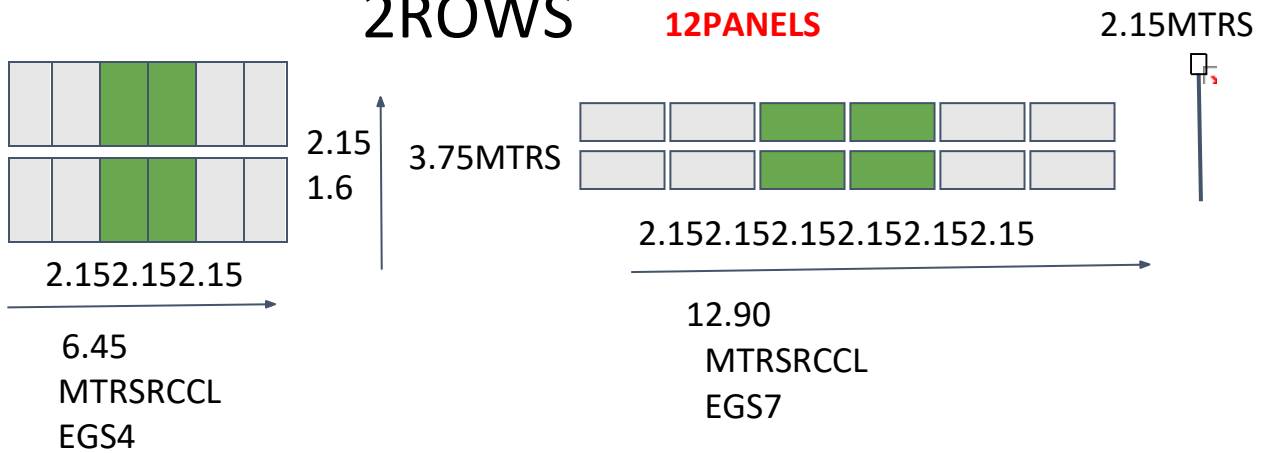

**8 PANELS**

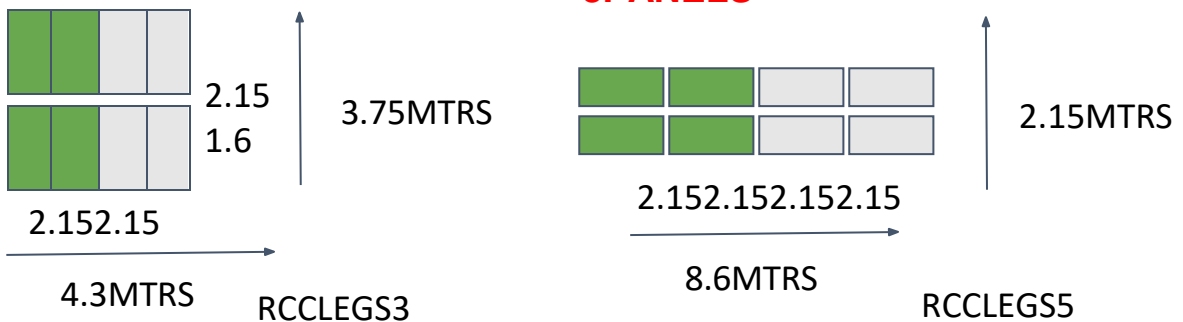

**6 PANELS**

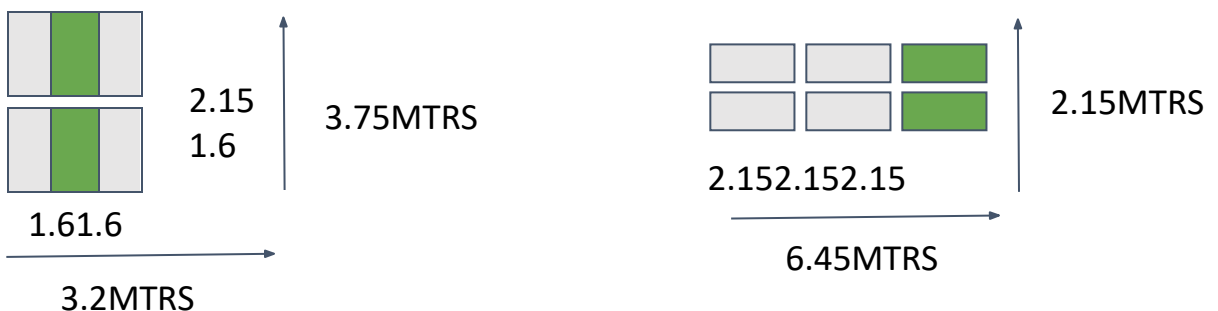

RCCLEGS3

RCCLEGS4

# 72CELLS1960X990mm

**18PANELS**      **3ROWS**

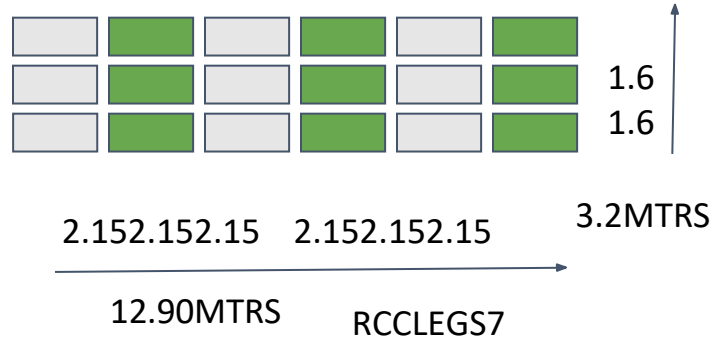
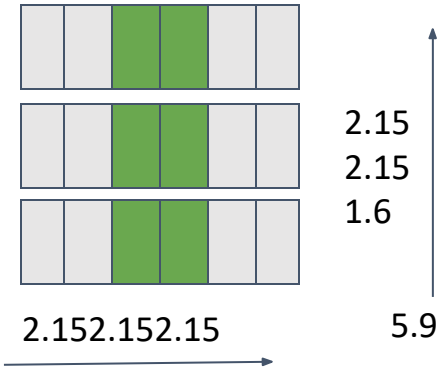

6.45MTRS    MTRS RCCLEGS4

12.90MTRS    RCCLEGS7

**12PANELS**

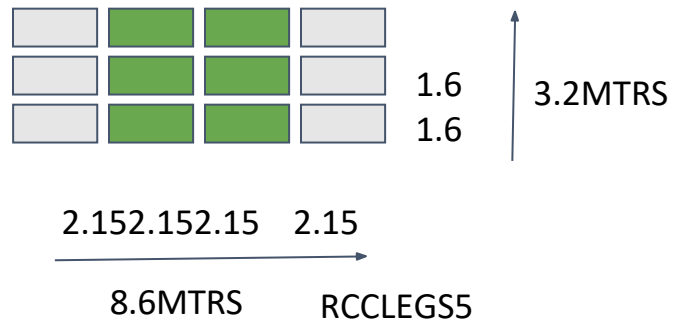
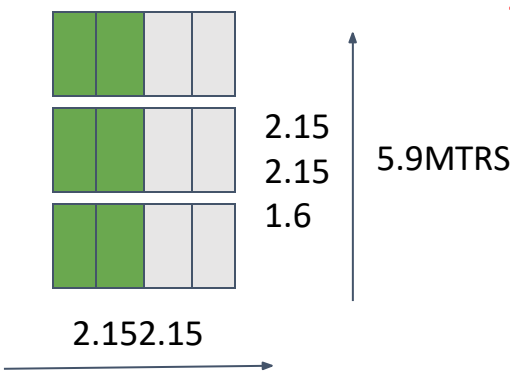

4.3MTRS    RCCLEGS3

8.6MTRS    RCCLEGS5

**9PANELS**

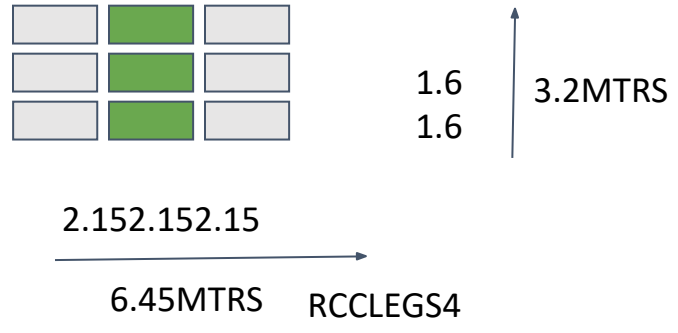
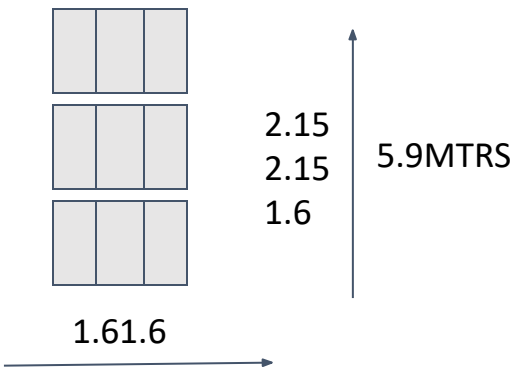

3.2MTRS    RCCLEGS3

6.45MTRS    RCCLEGS4

**6PANELS**

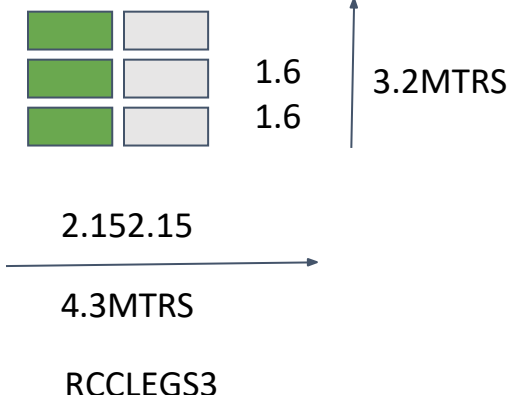
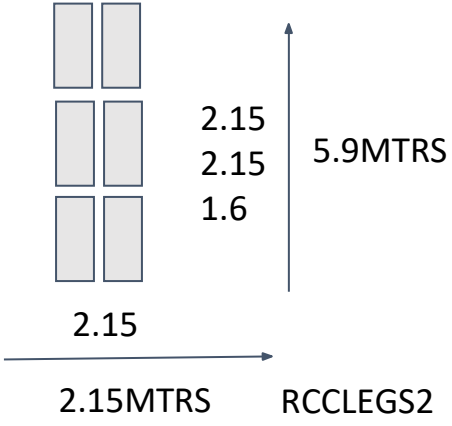

2.15MTRS    RCCLEGS2

4.3MTRS    RCCLEGS3

# 18DEGREEELEVATION

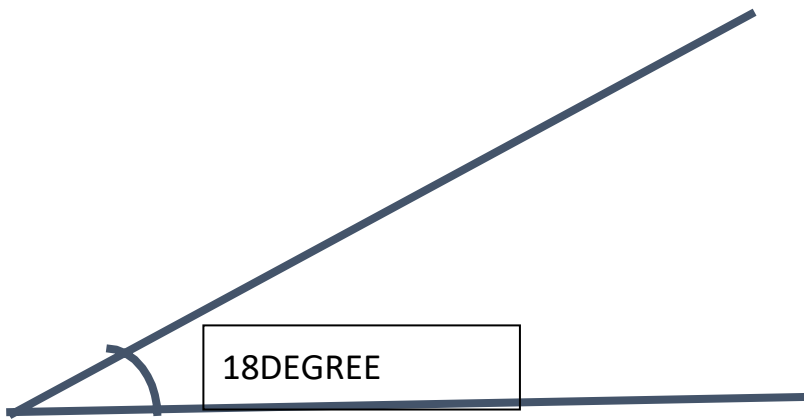

18Degree  
Elevation

# RCCLEGSETS 1.6MTRRAFTOR

1600

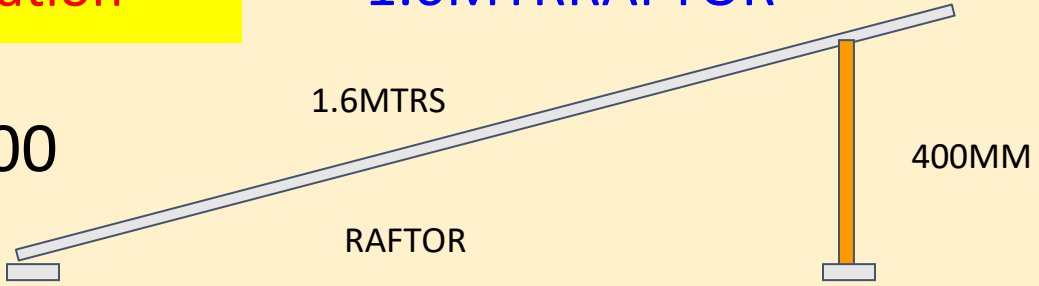

1604

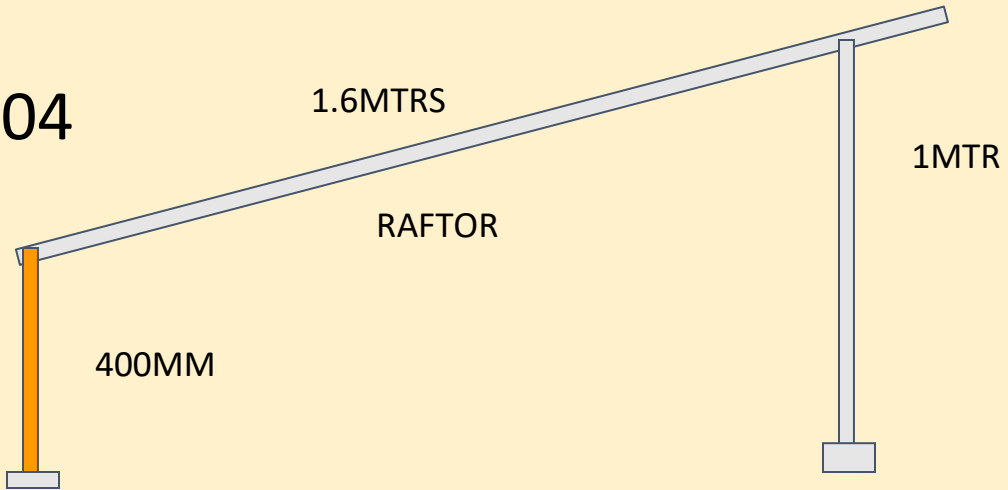

1610

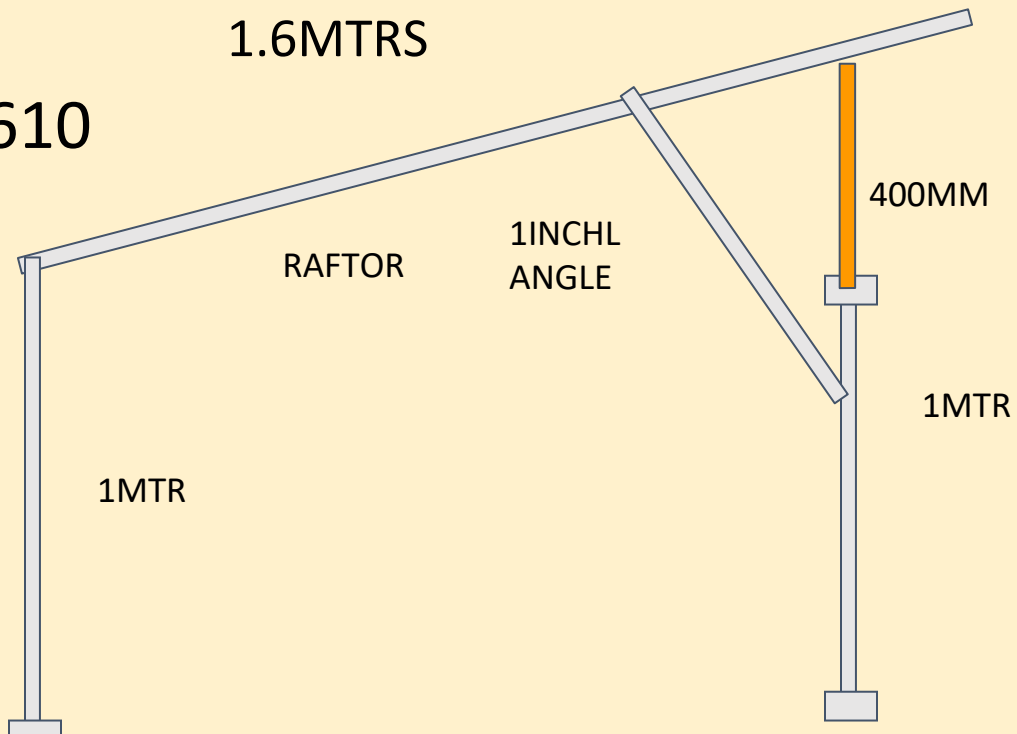

18Degree  
Elevation

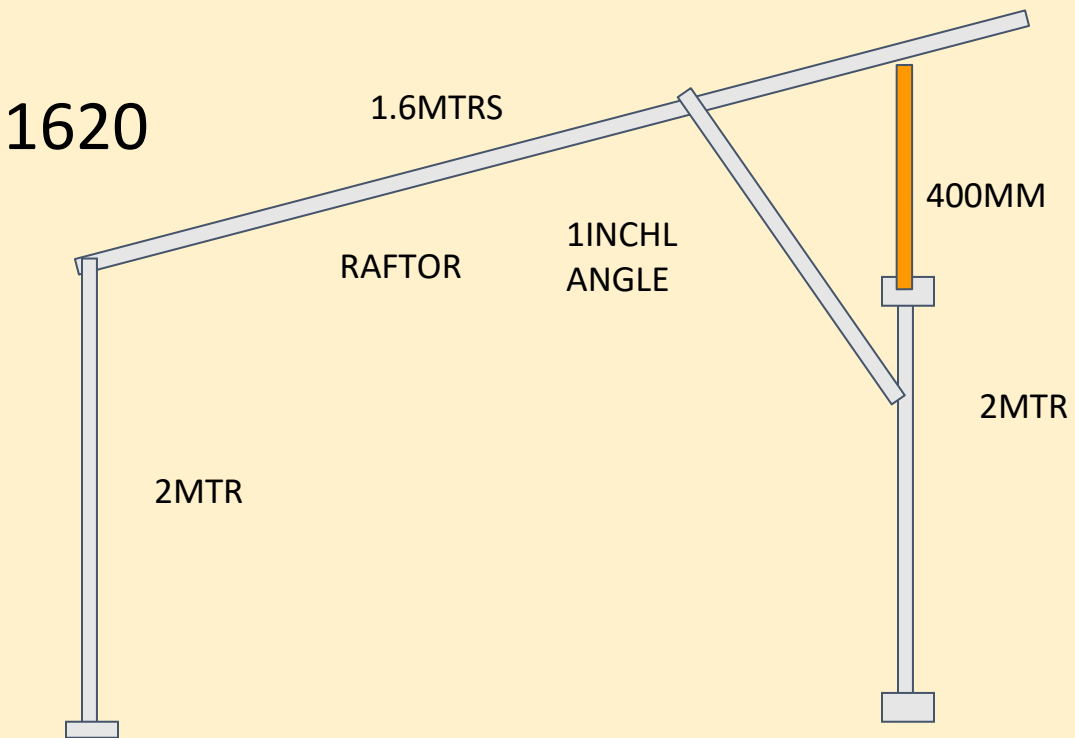
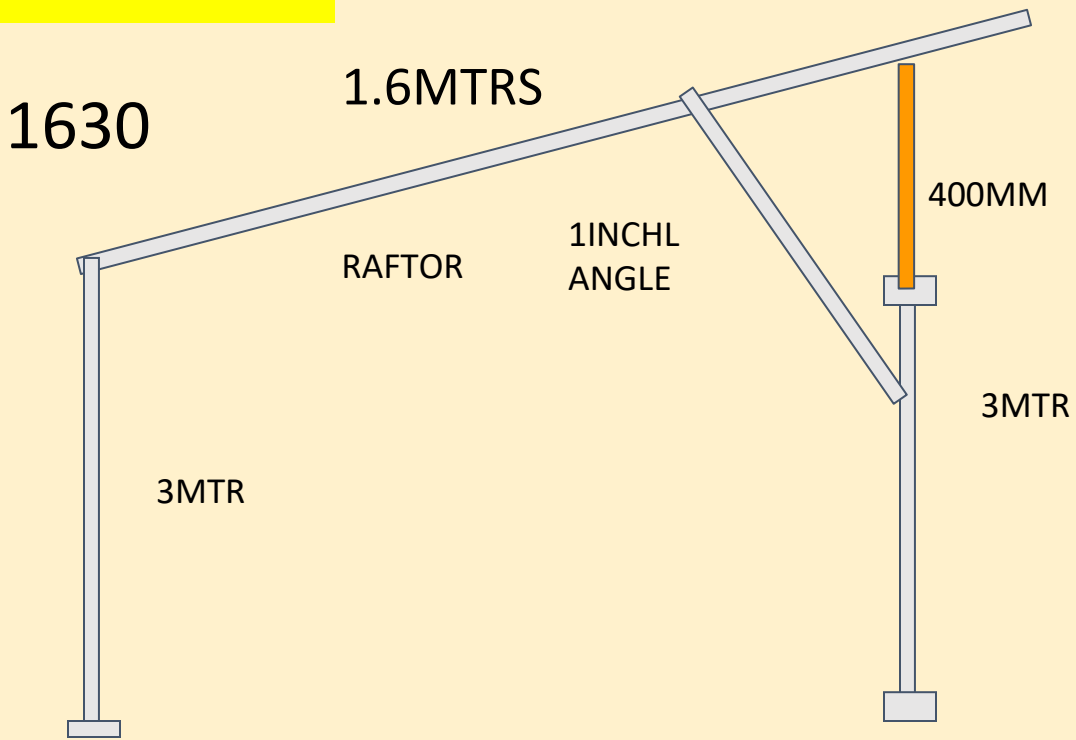

18Degree  
Elevation

RCCLEGSETS  
2.15MTRRAFTOR

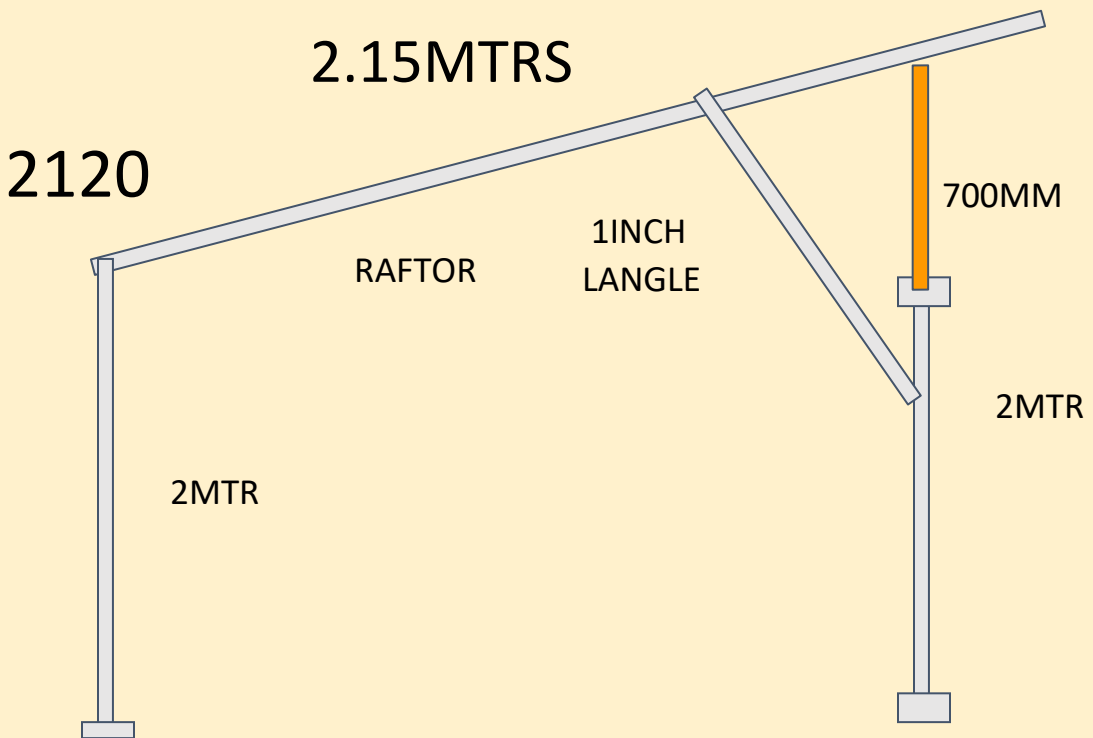
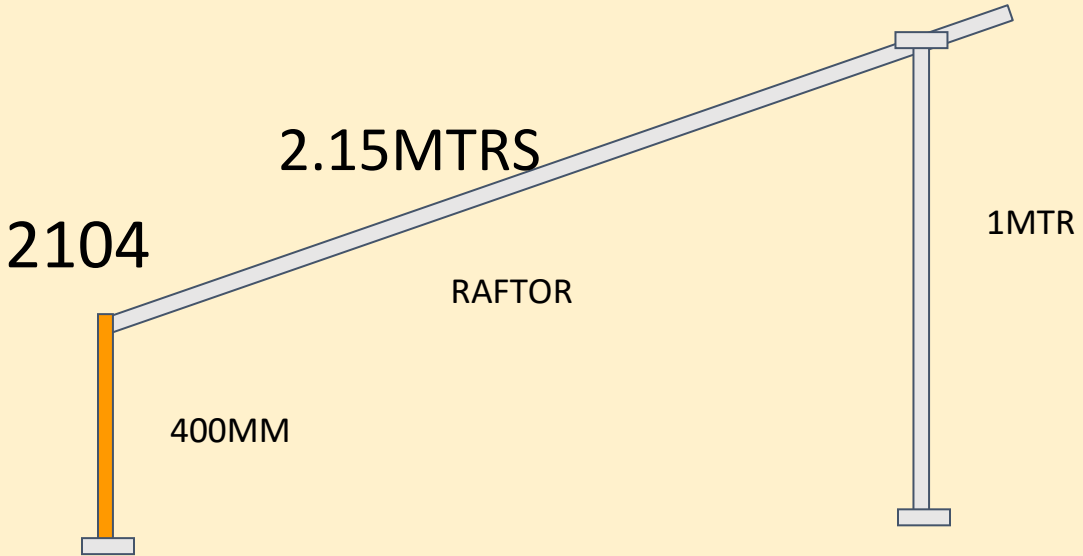
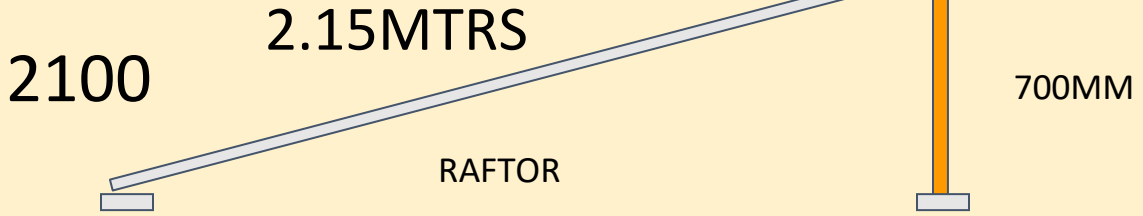



18Degree  
Elevation

RCCLEGSETS  
1MTRFRONTLEG

2.15MTRS

2110

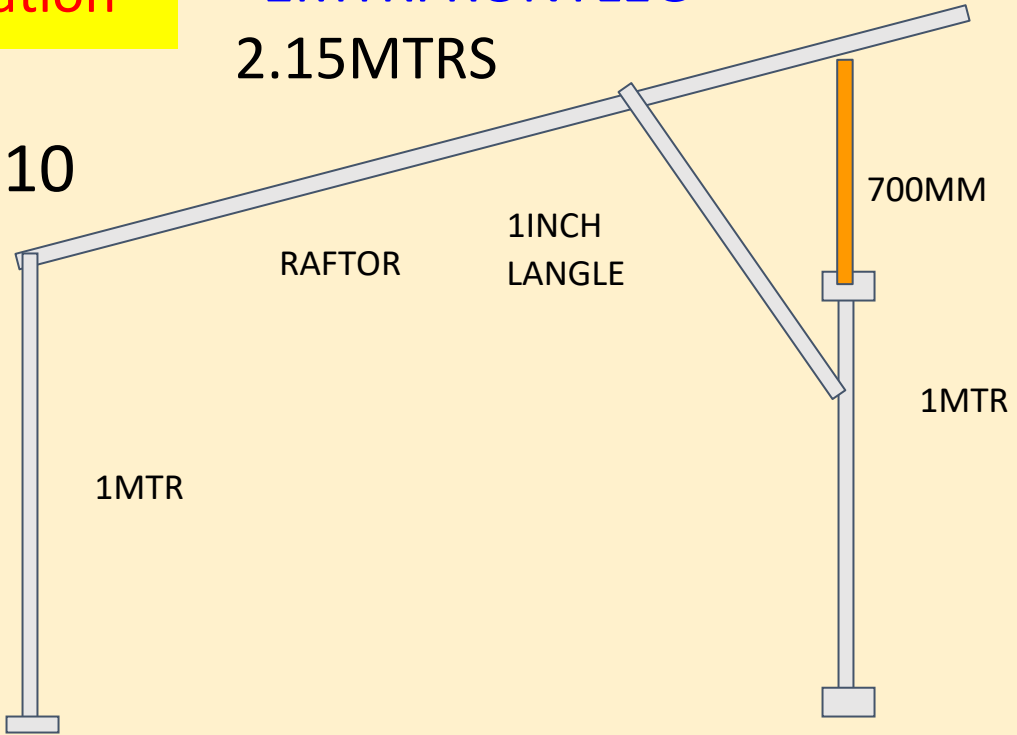

2.15MTRS

2130

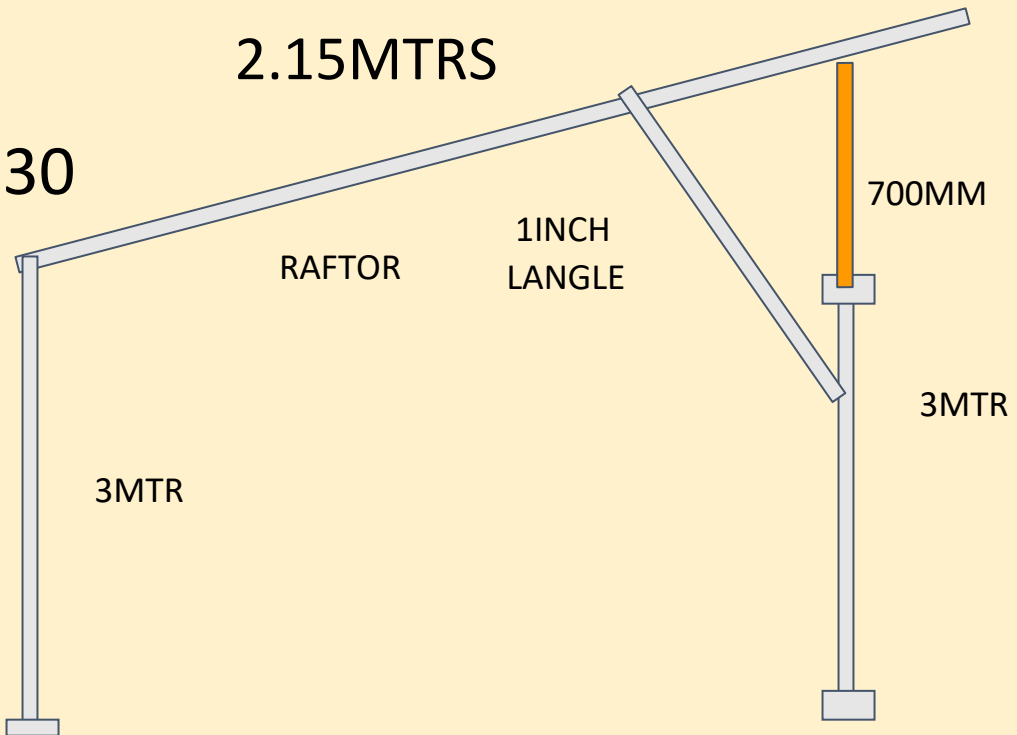

18Degree  
Elevation

RCCLEGSETS  
3.2MTRRAFTOR

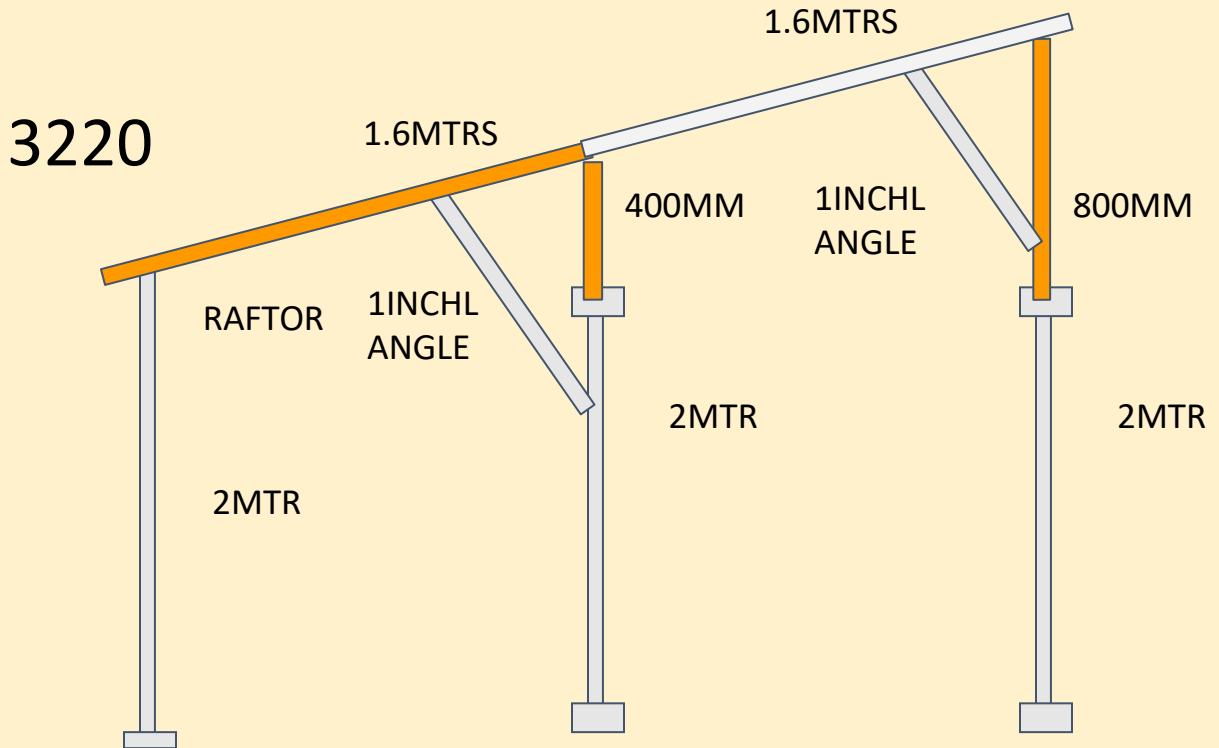
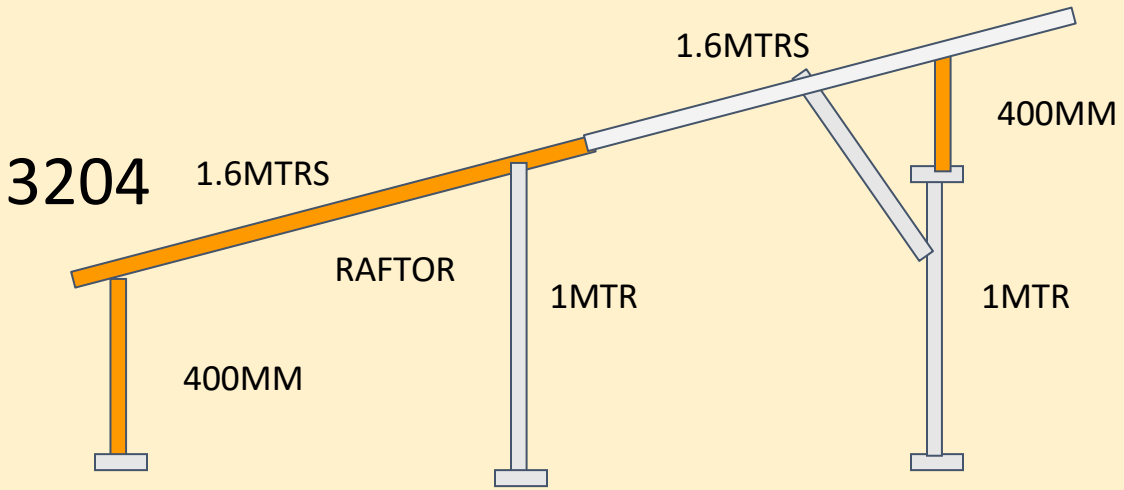
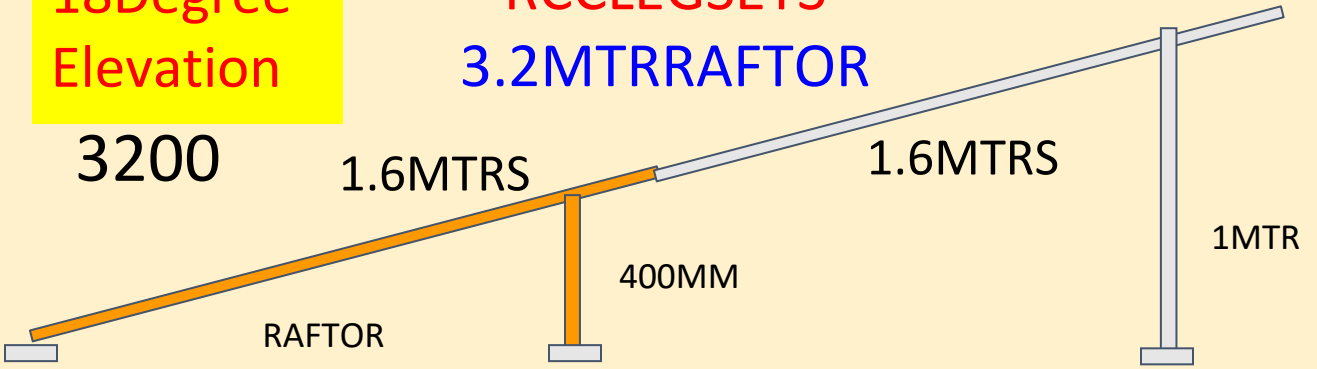



18Degree  
Elevation

# RCCLEGSETS3.75M TRRAFTOR

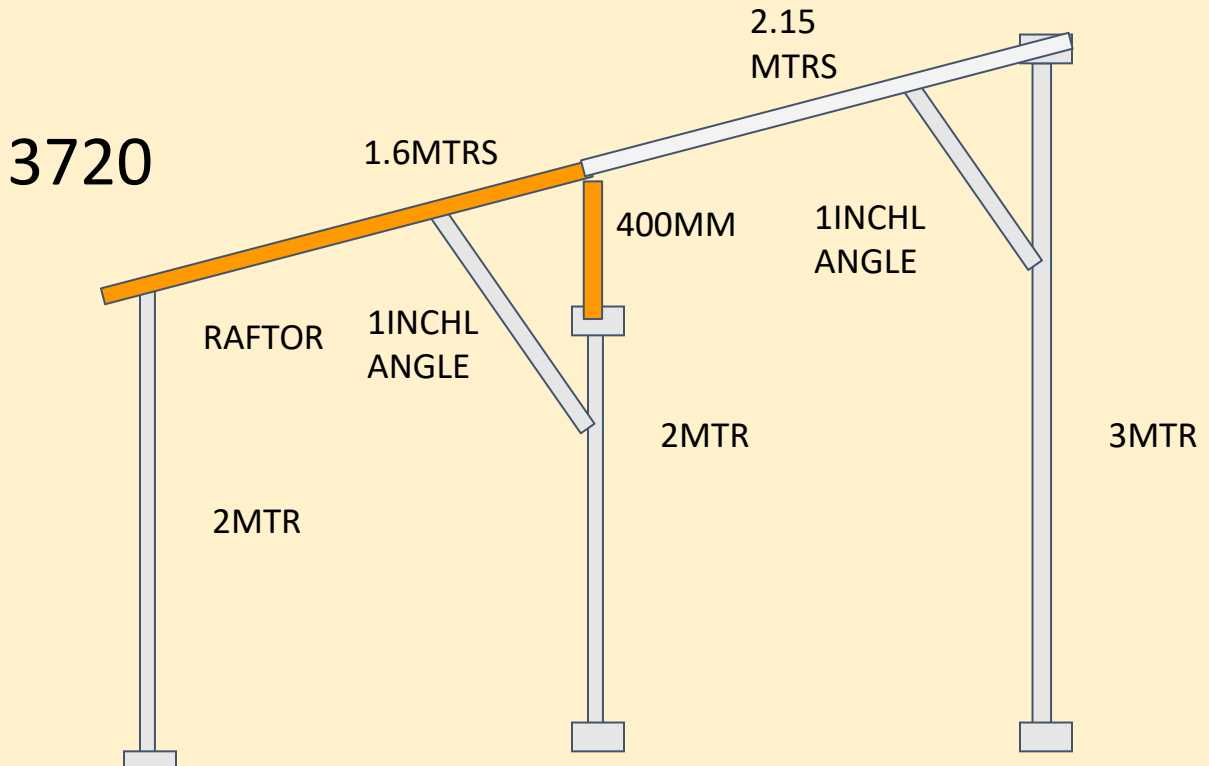
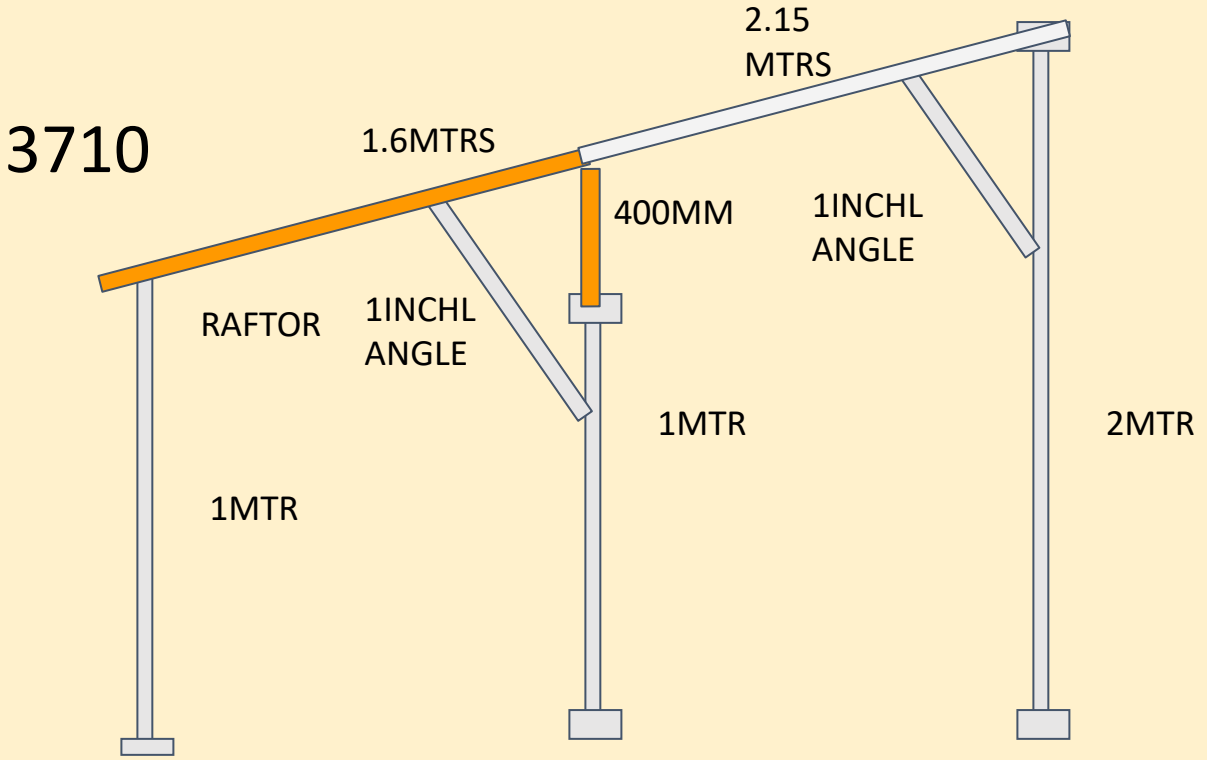

18Degree  
Elevation

RCCLEGSETS  
4.3MTRRAFTOR

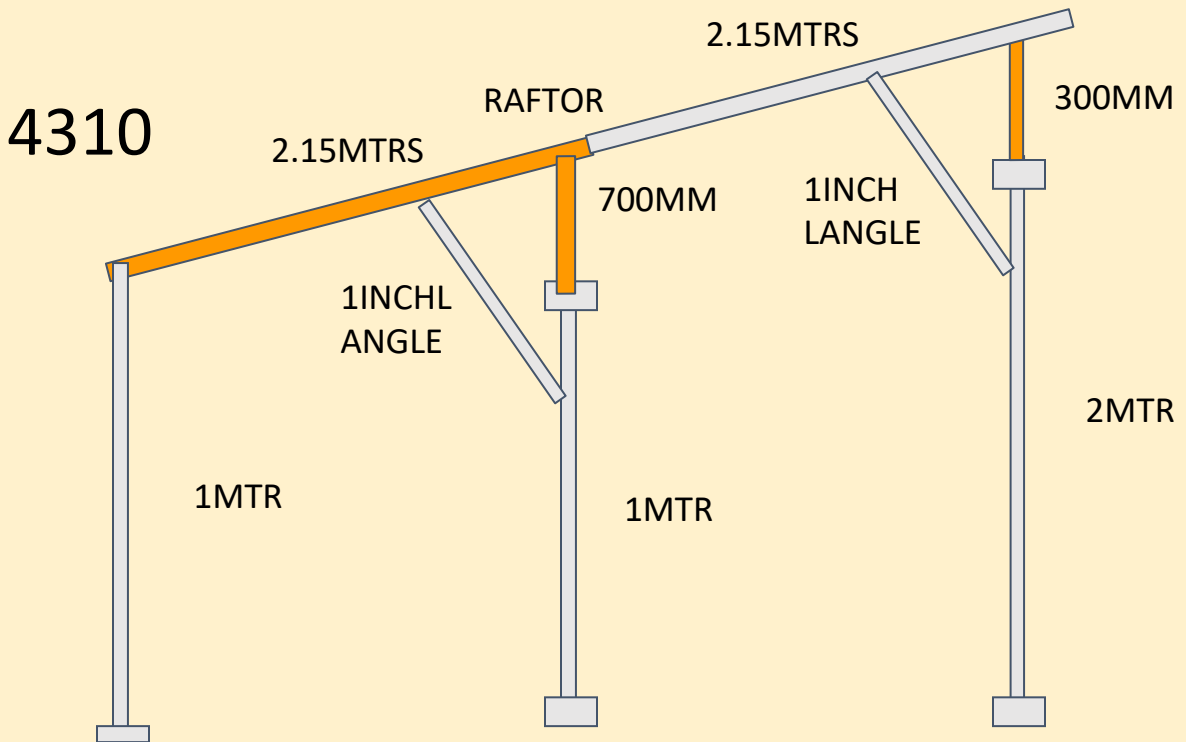
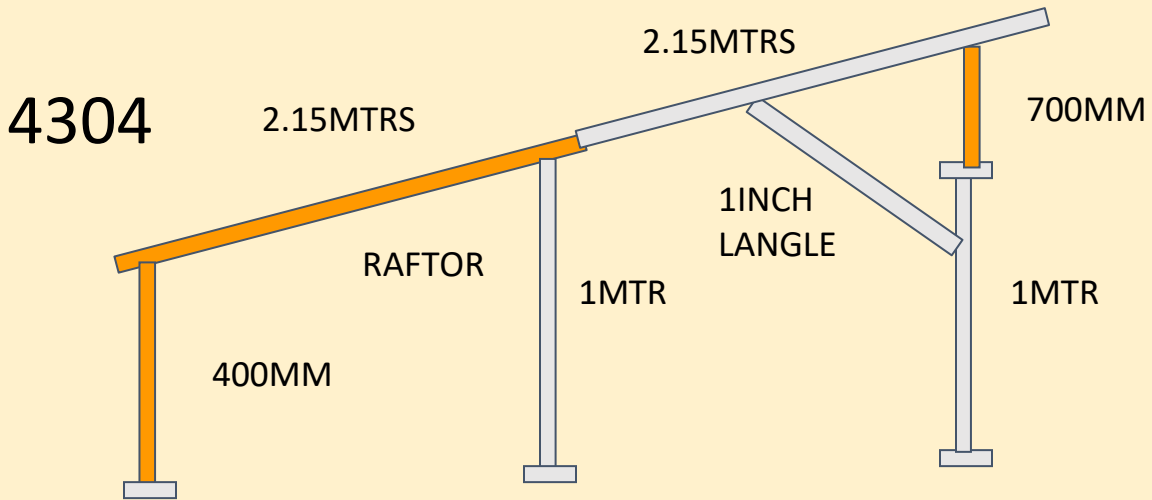
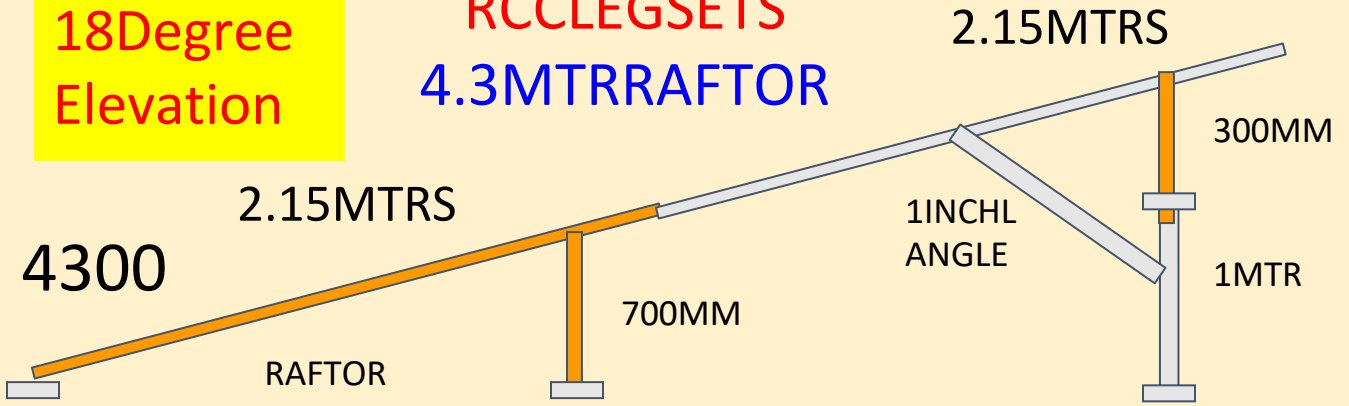

18Degree  
Elevation

# RCCLEGSETS 4.3MTRRAFTOR

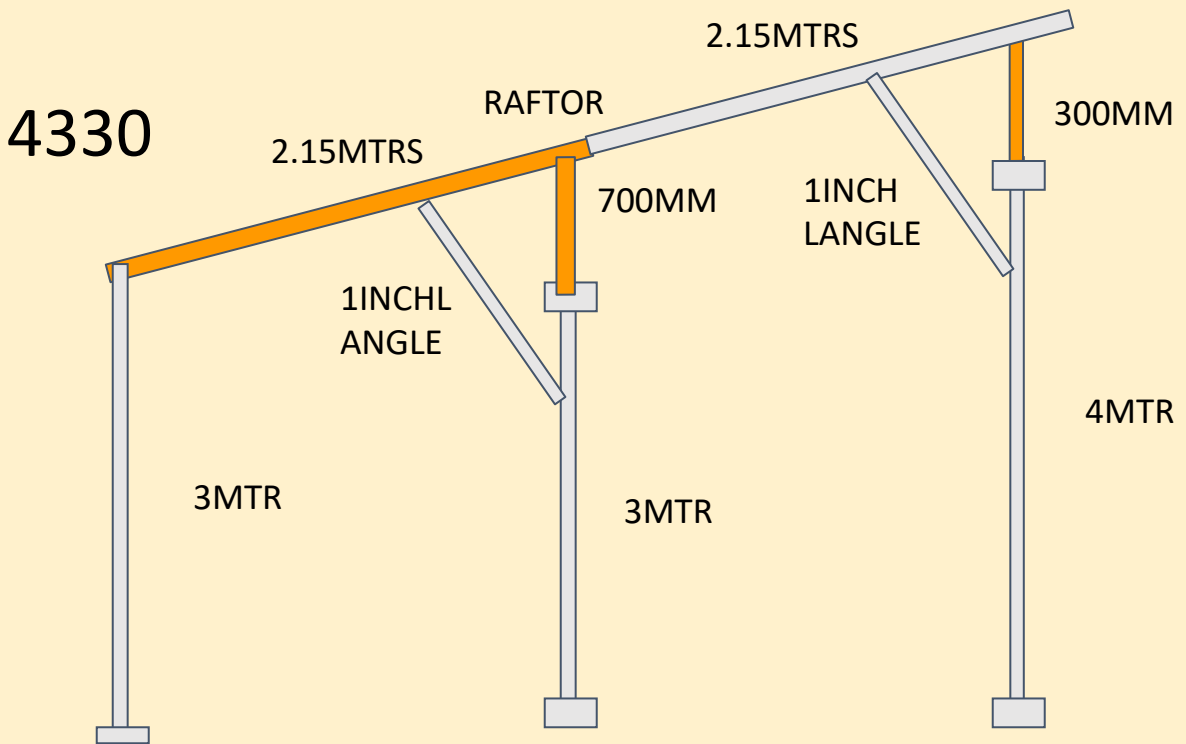
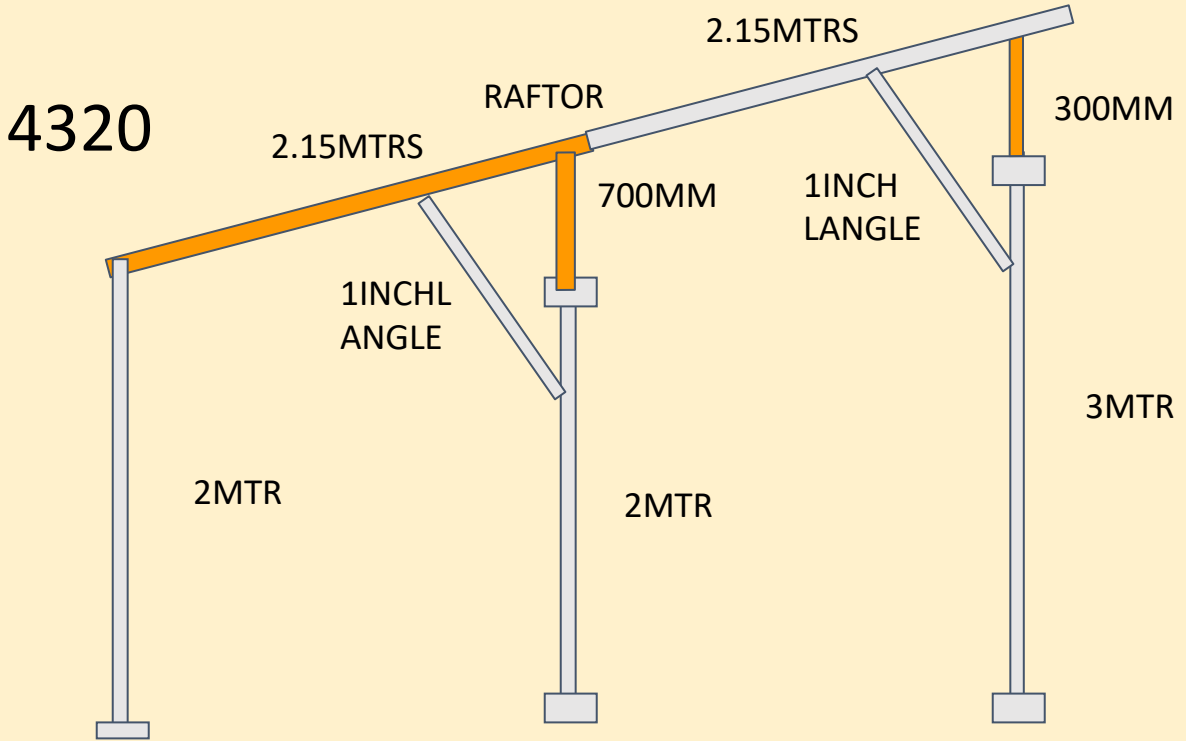

18Degree  
Elevation

RCCLEGSETS  
5.9MTRRAFTOR

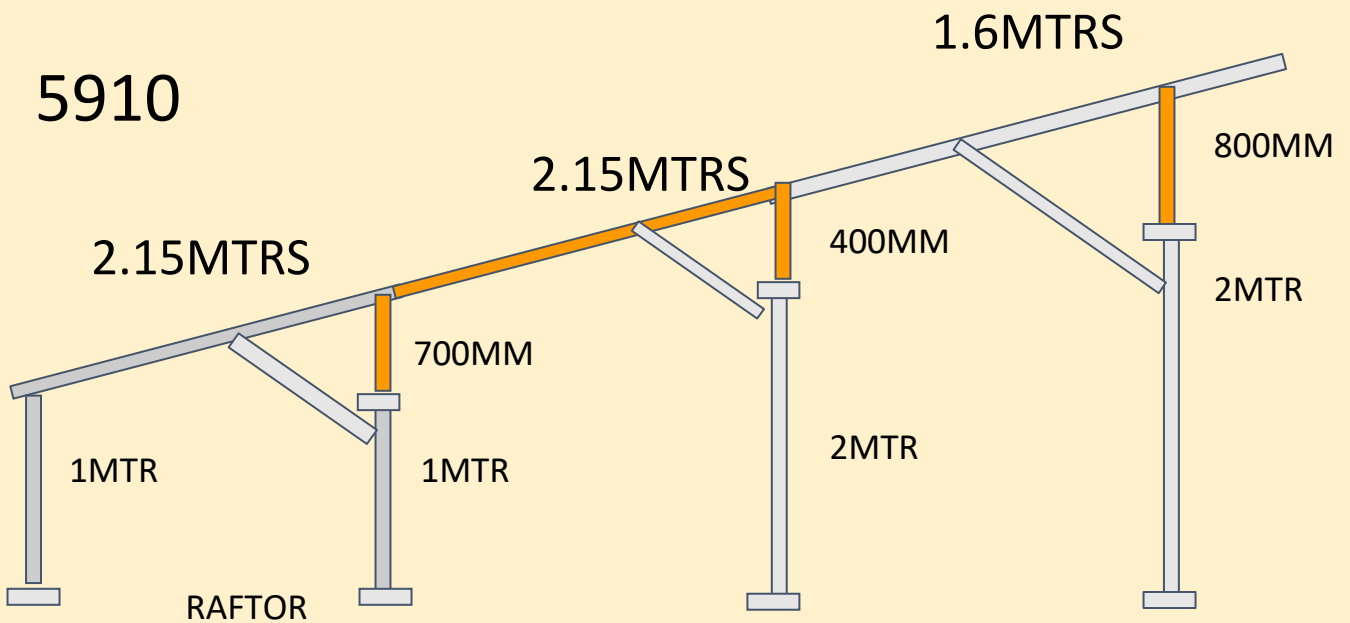
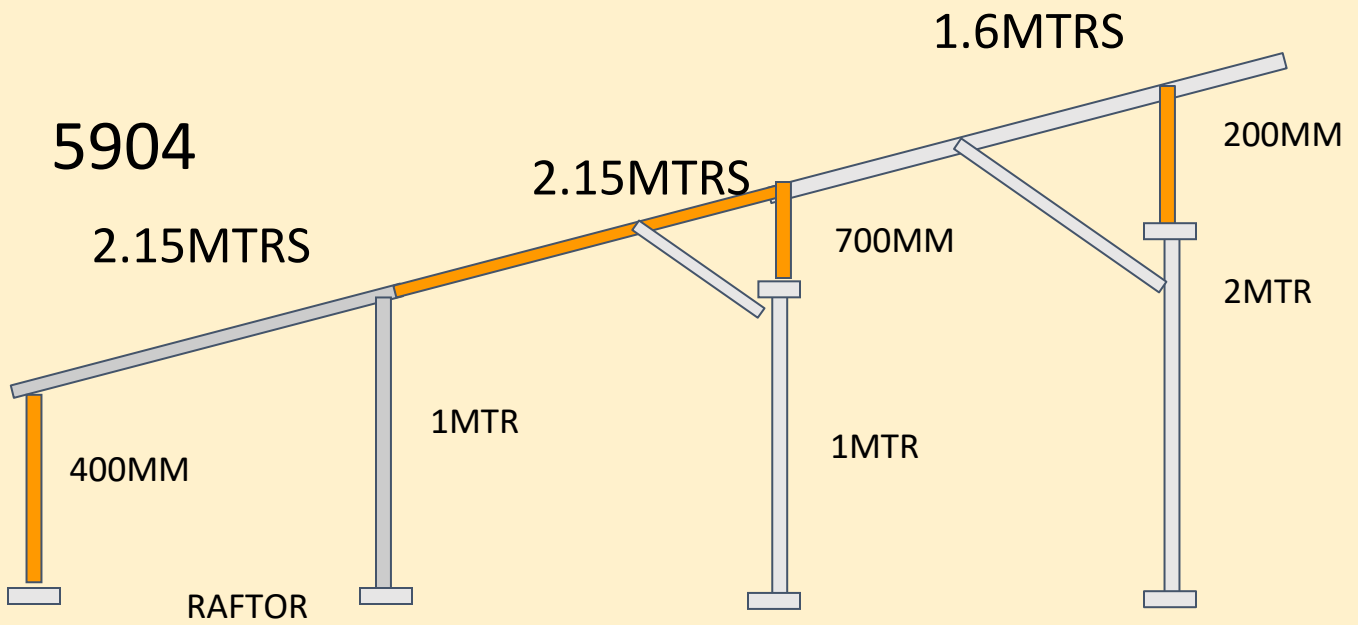
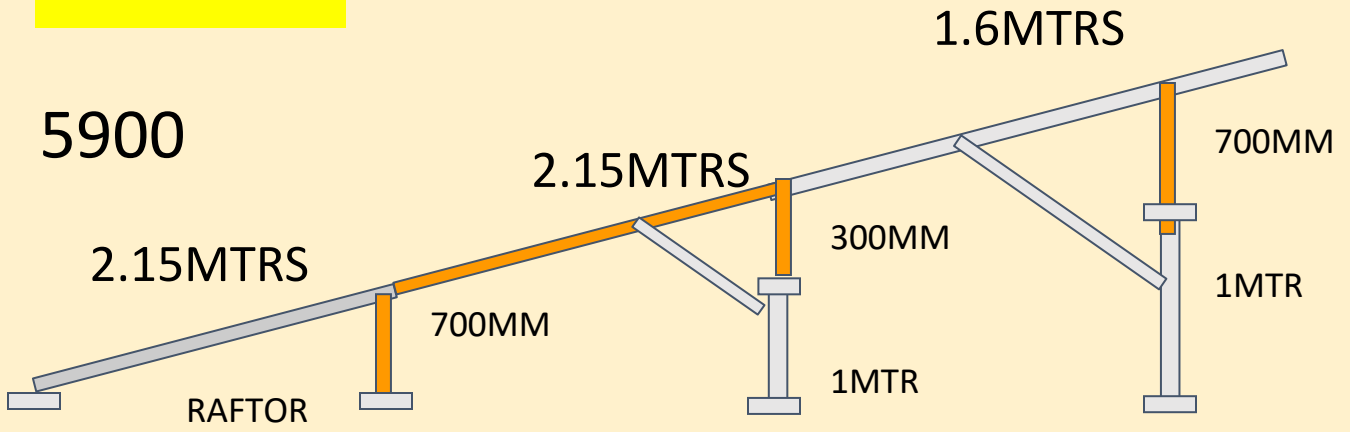

18Degree  
Elevation

RCCLEGSETS  
5.9MTRRAFTOR

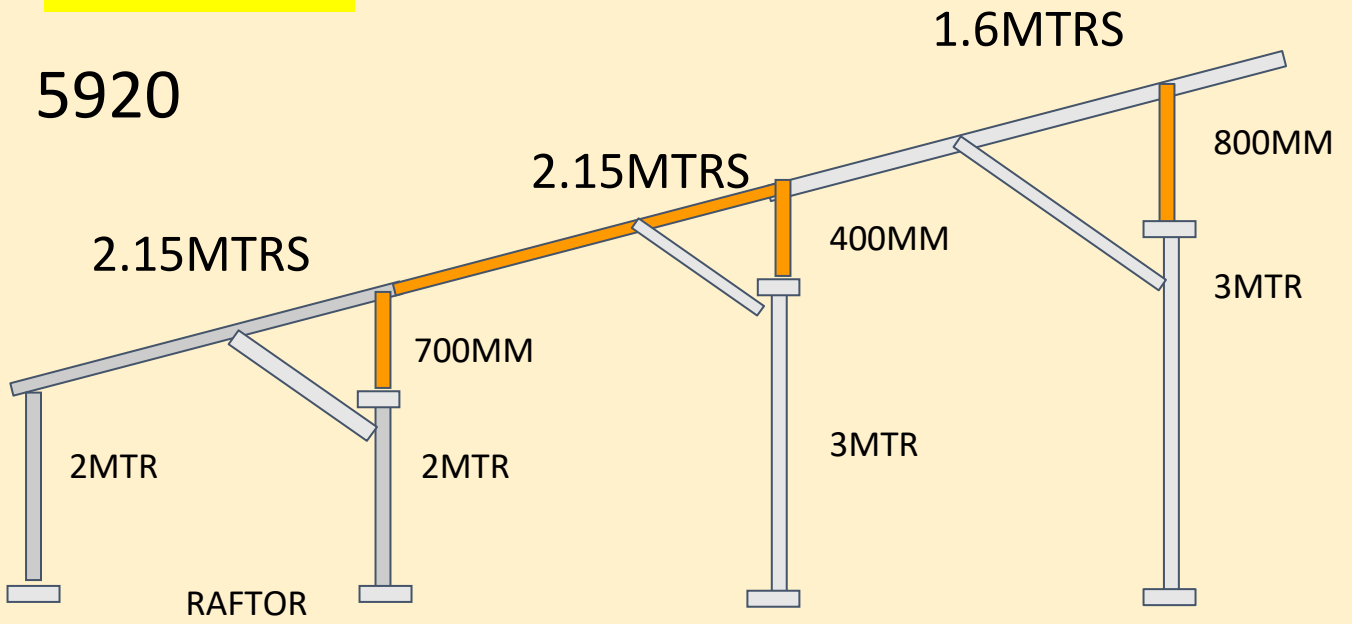



# 11DEGREEELEVATION

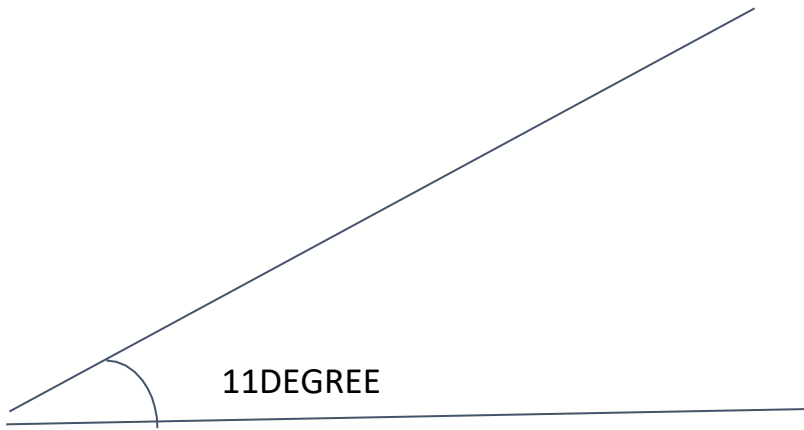

11Degree  
Elevation

# RCCLEGSETS3.75M TRRAFTOR

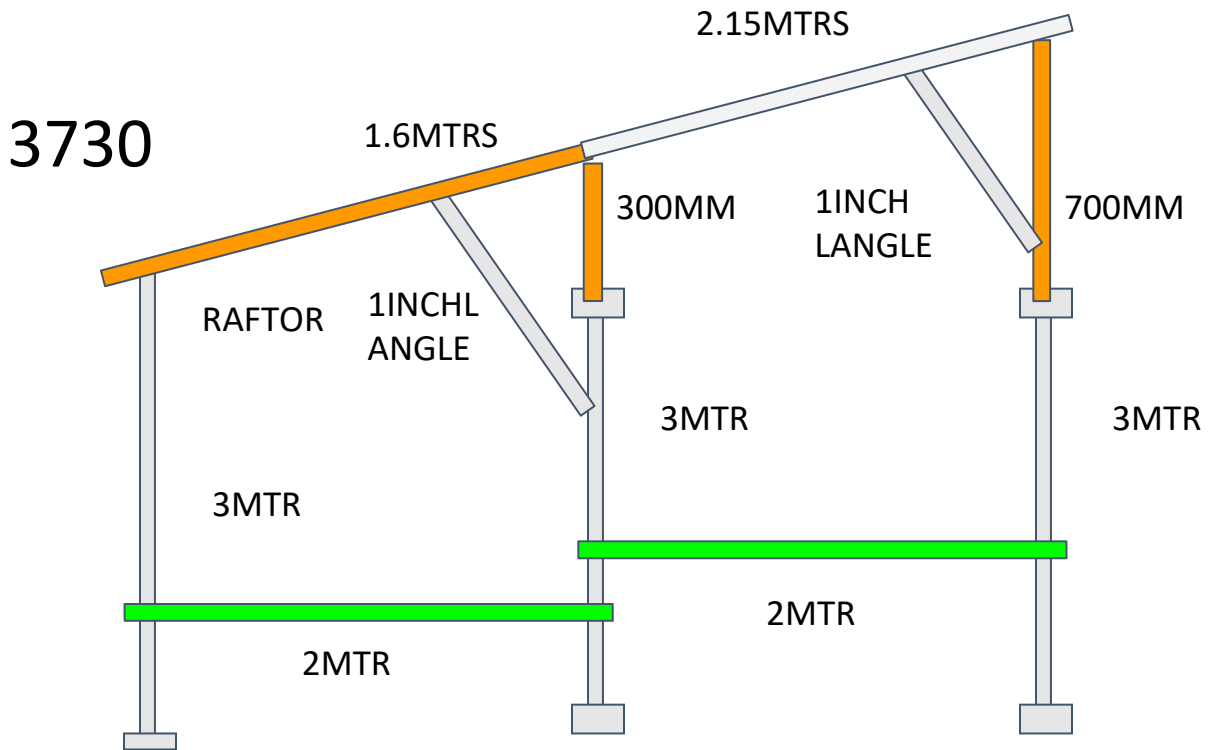
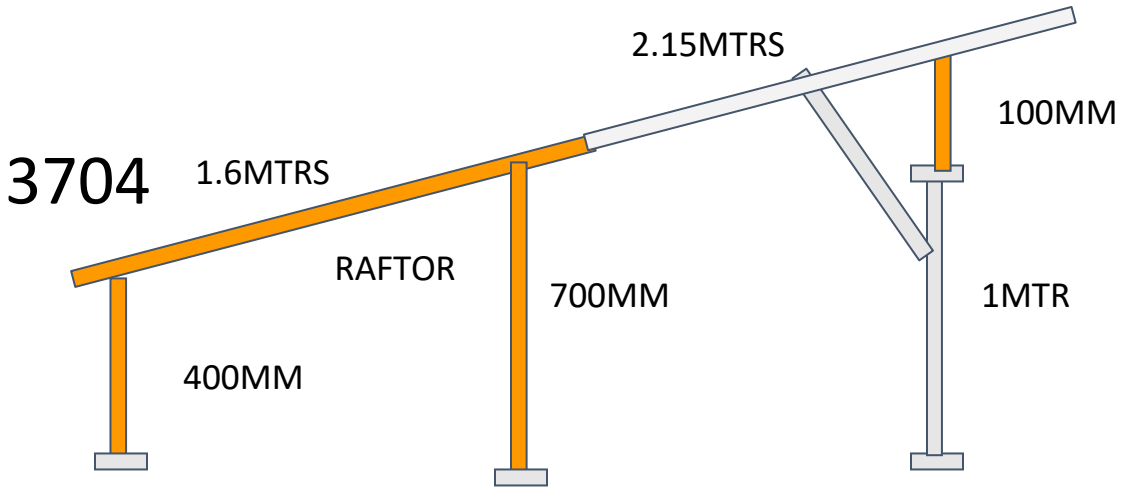
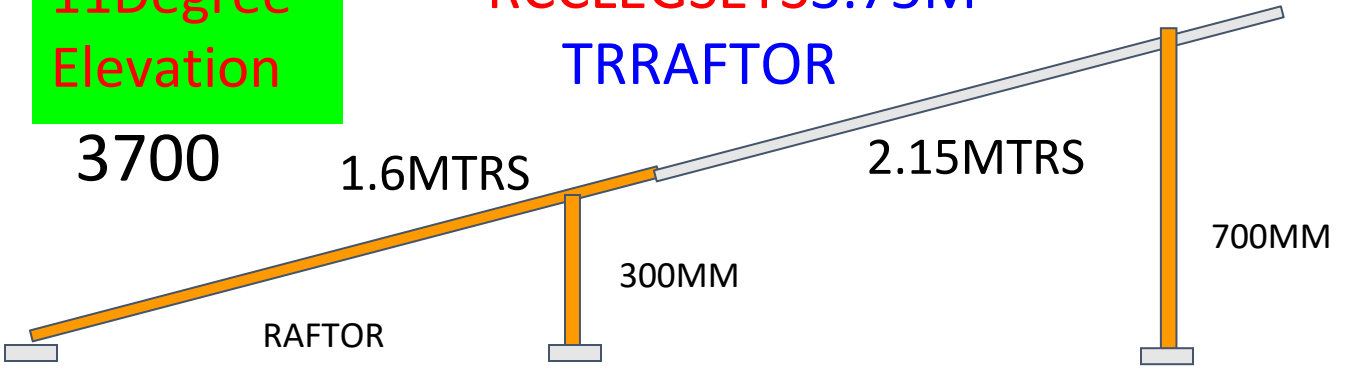

11Degree  
Elevation

# RCCLEGSETS3.75M TRRAFTOR

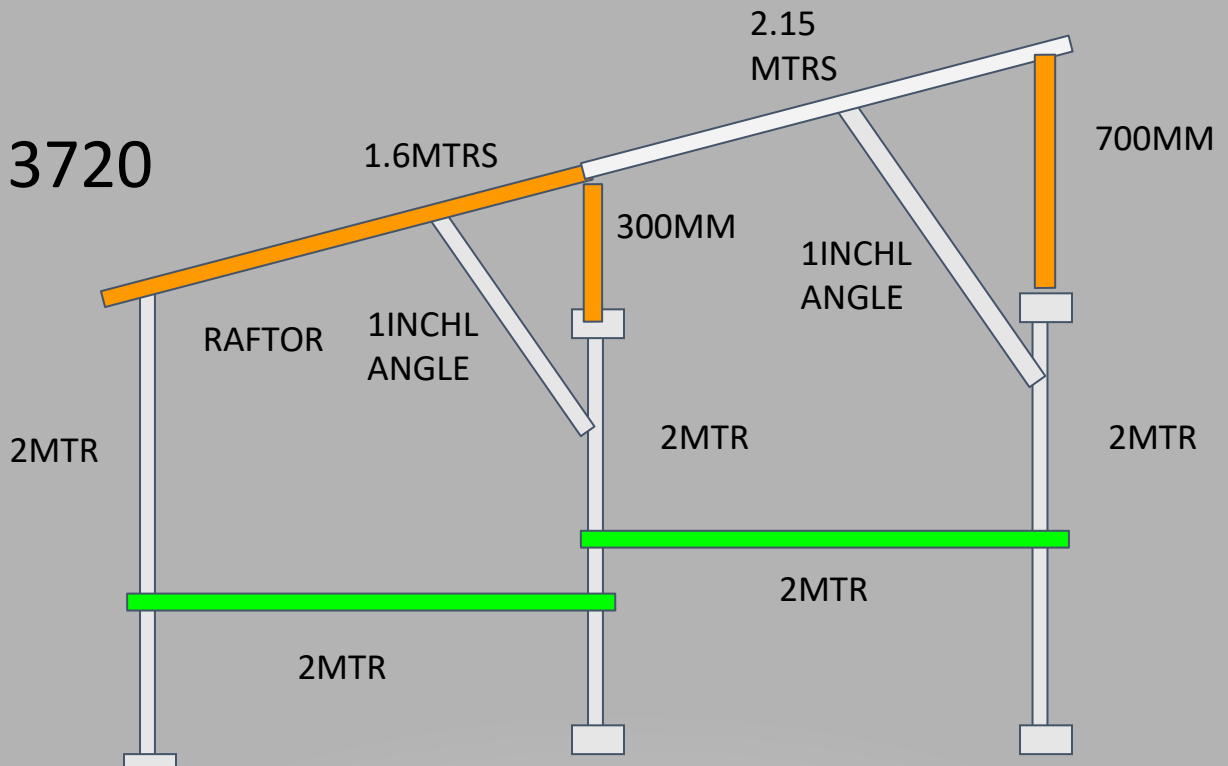
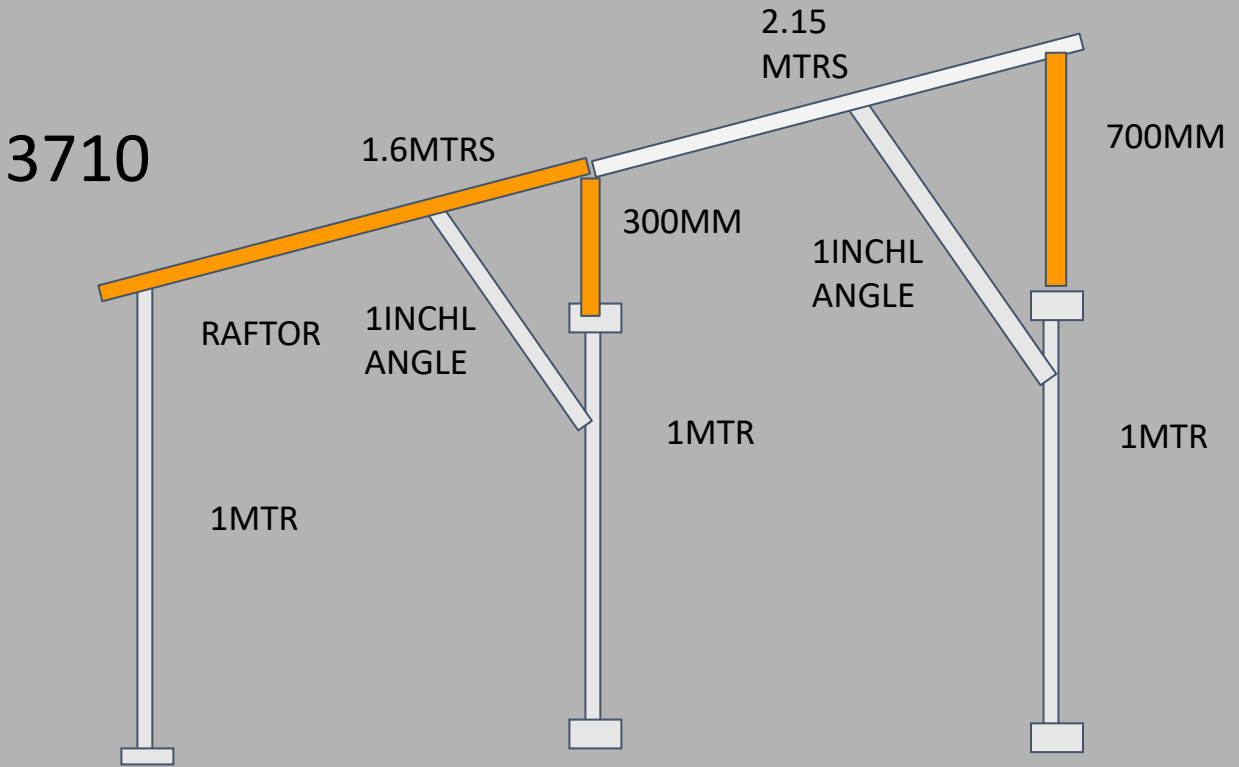

11Degree  
Elevation

RCCLEGSETS3.2MTRR  
AFTOR

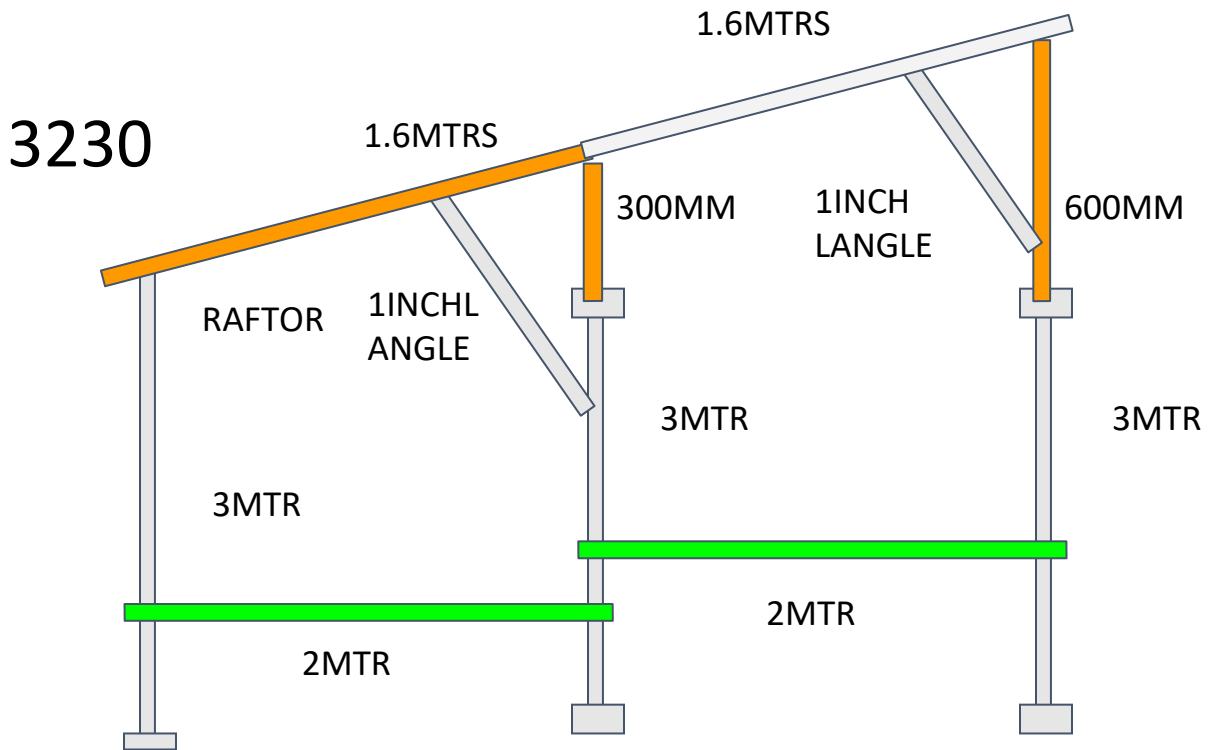
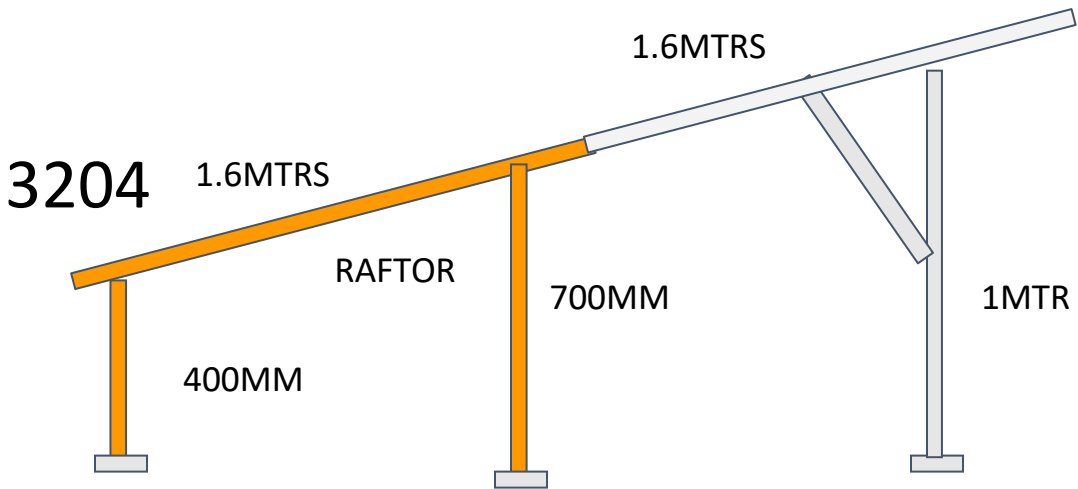
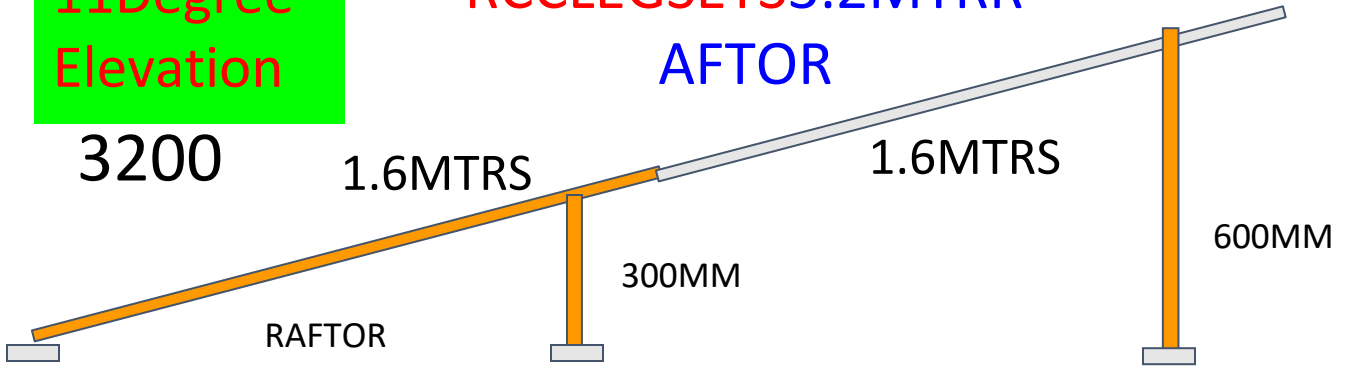

11Degree  
Elevation

RCCLEGSETS  
2.15MTRRAFTOR

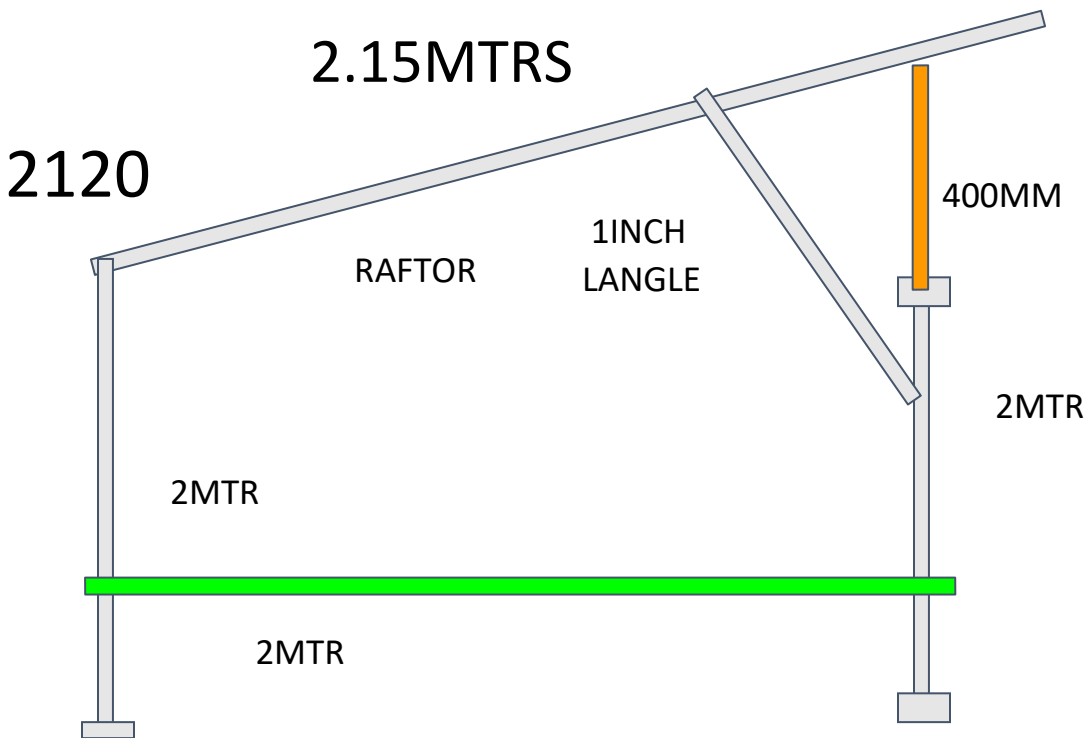
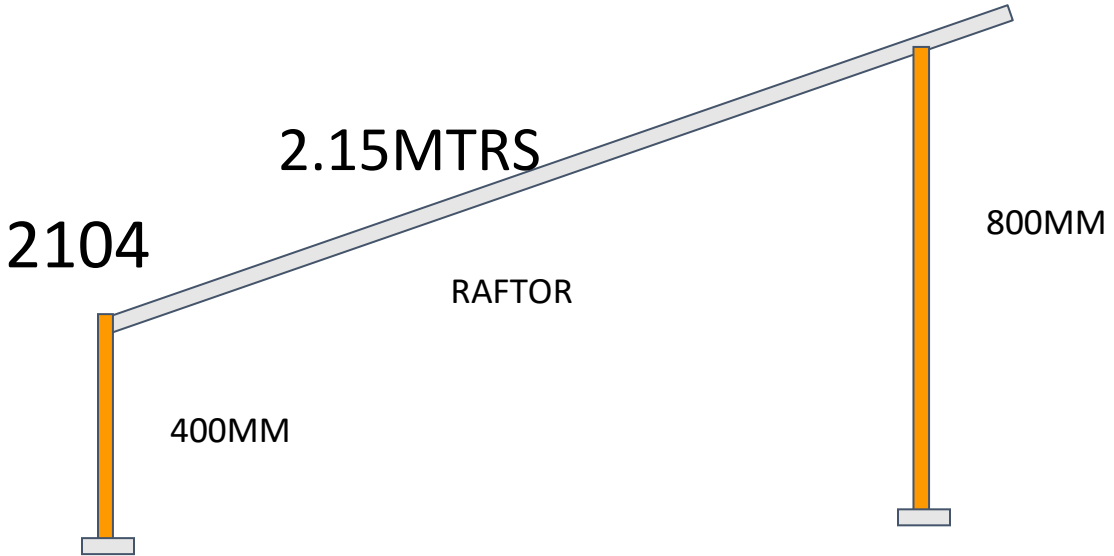
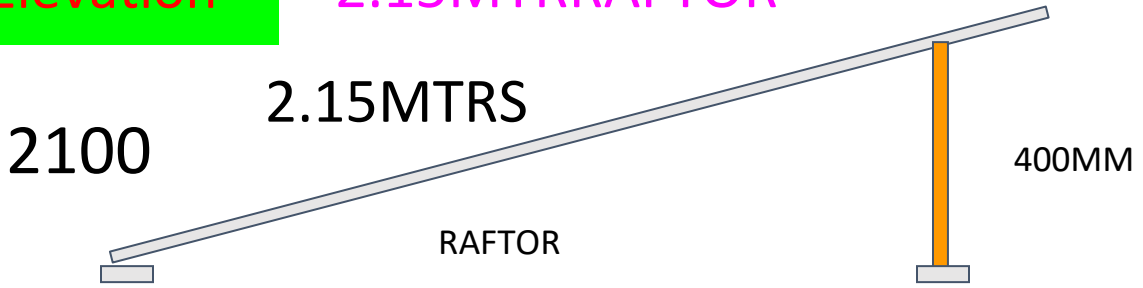

11Degree  
Elevation

RCCLEGSETS  
1MTRFRONTLEG

2.15MTRS

2110

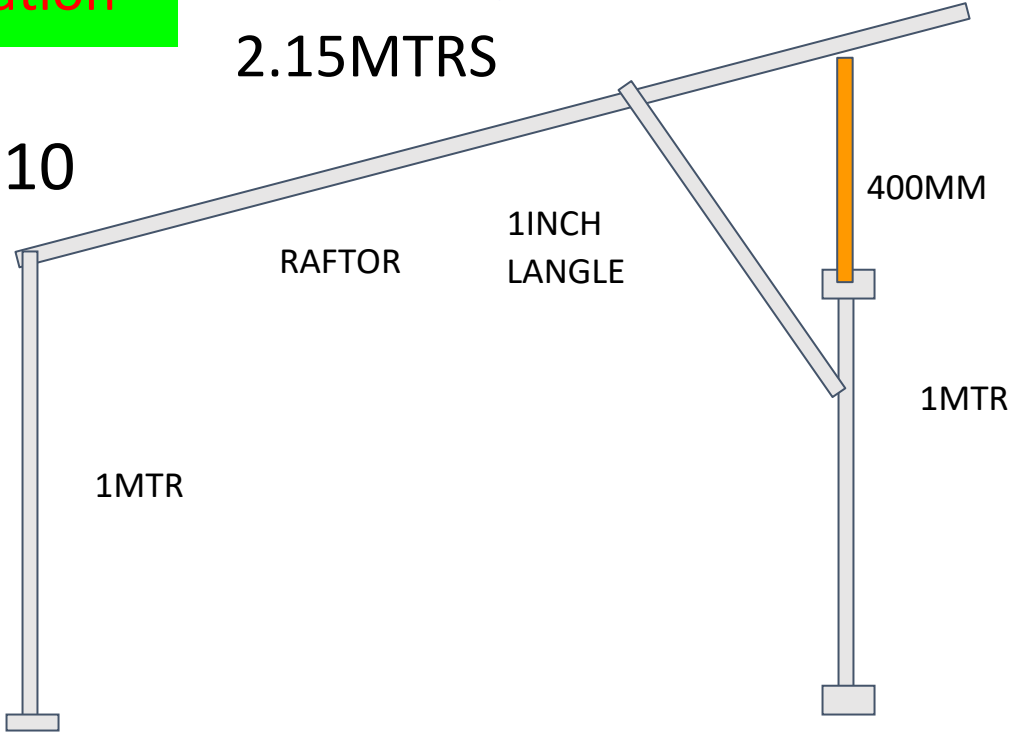

2130

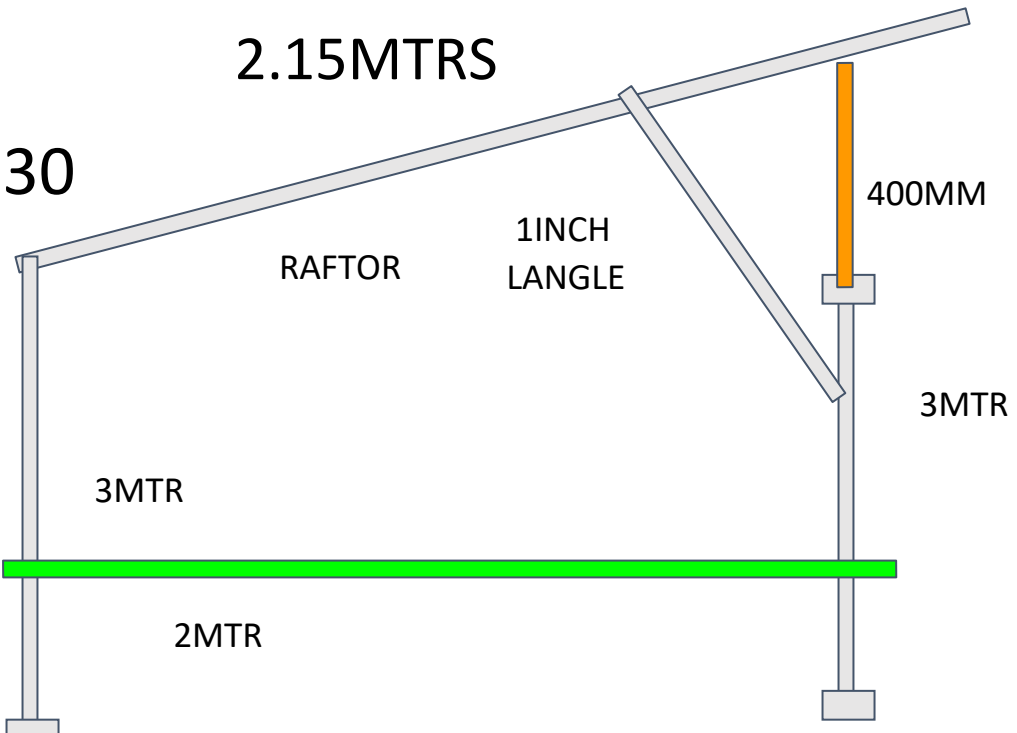

11Degree  
Elevation

# RCCLEGSETS 1.6MTRRAFTOR

1600

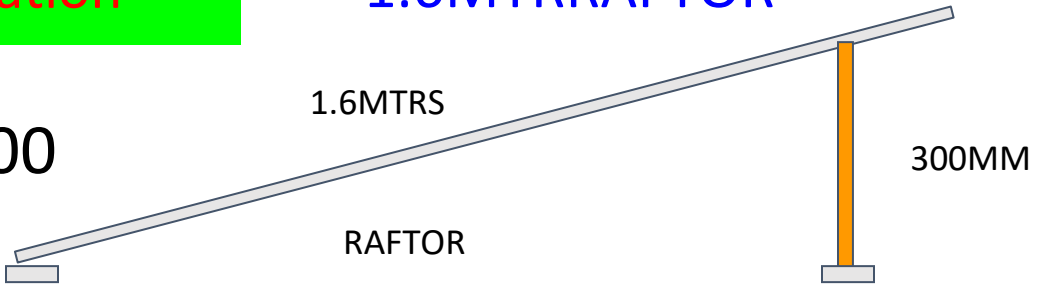

1604

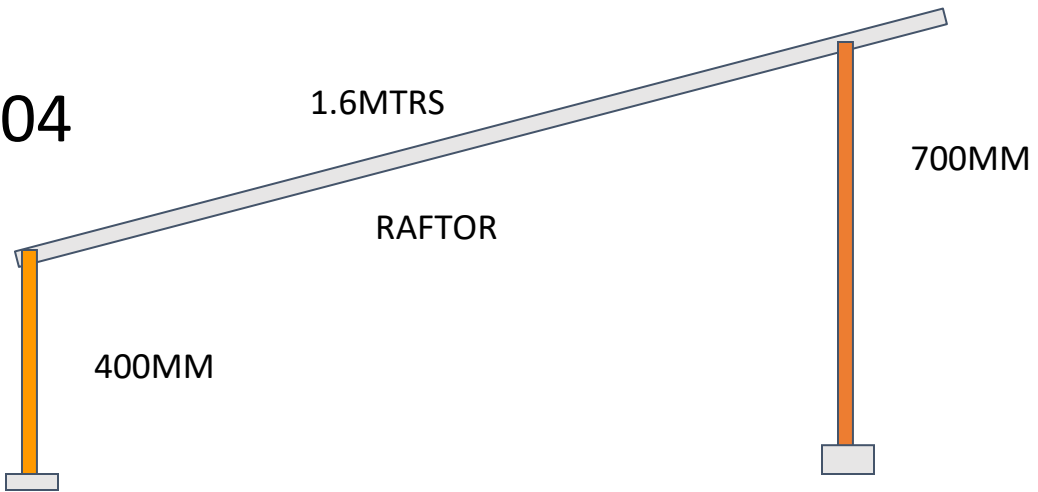

1610

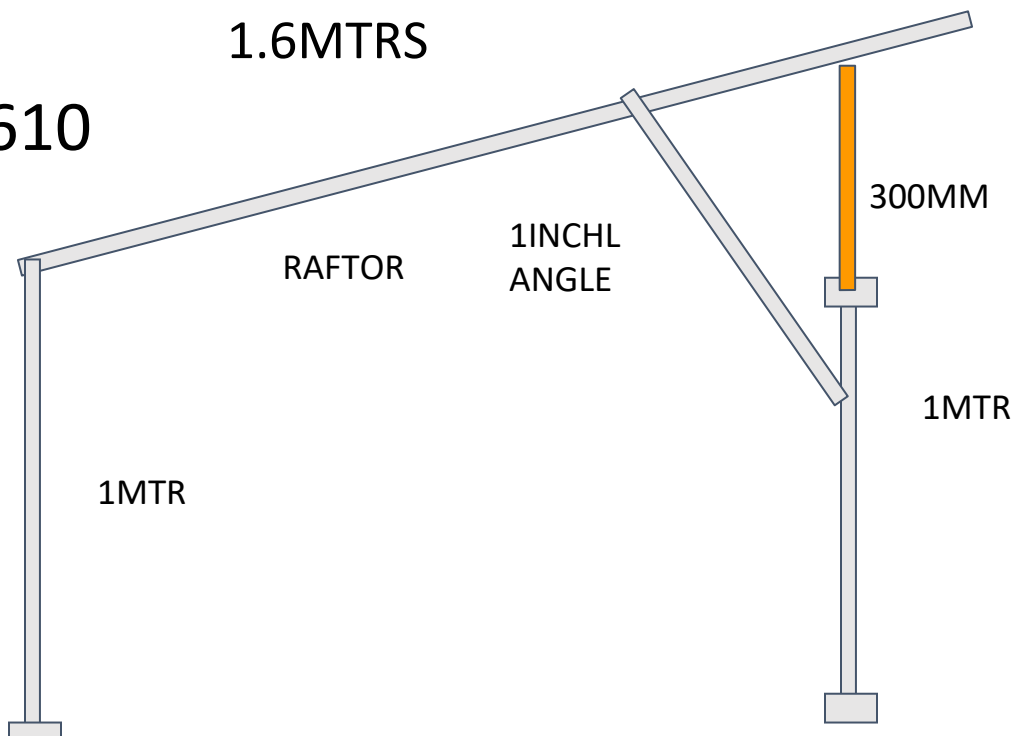

11Degree  
Elevation

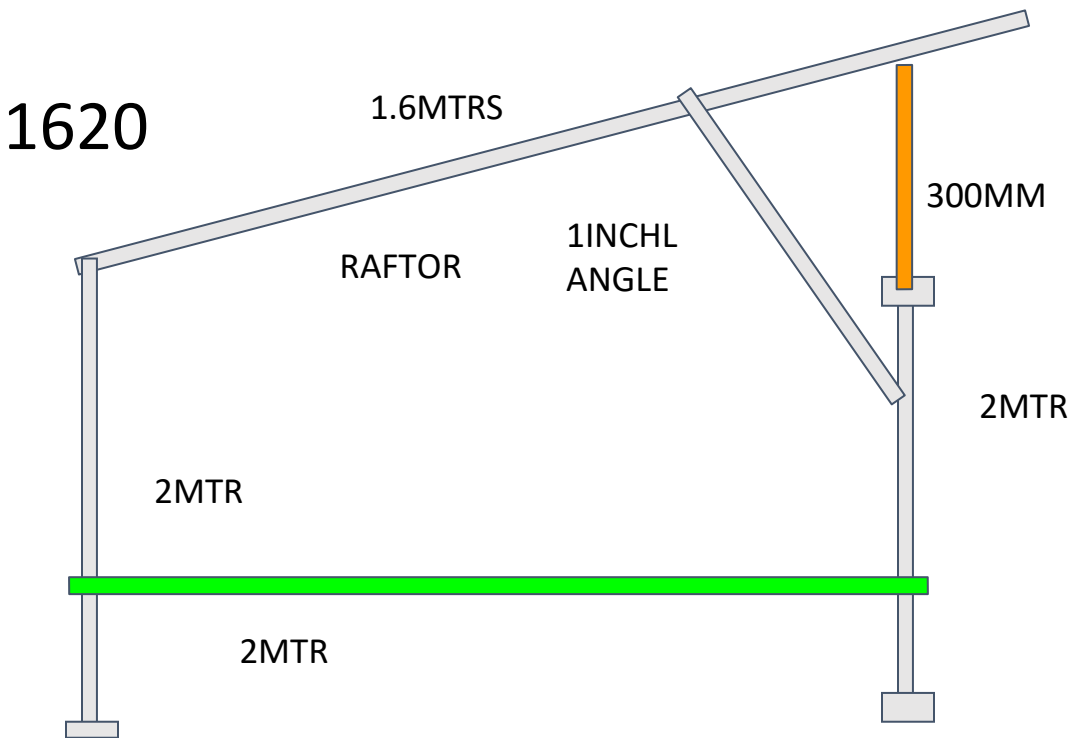
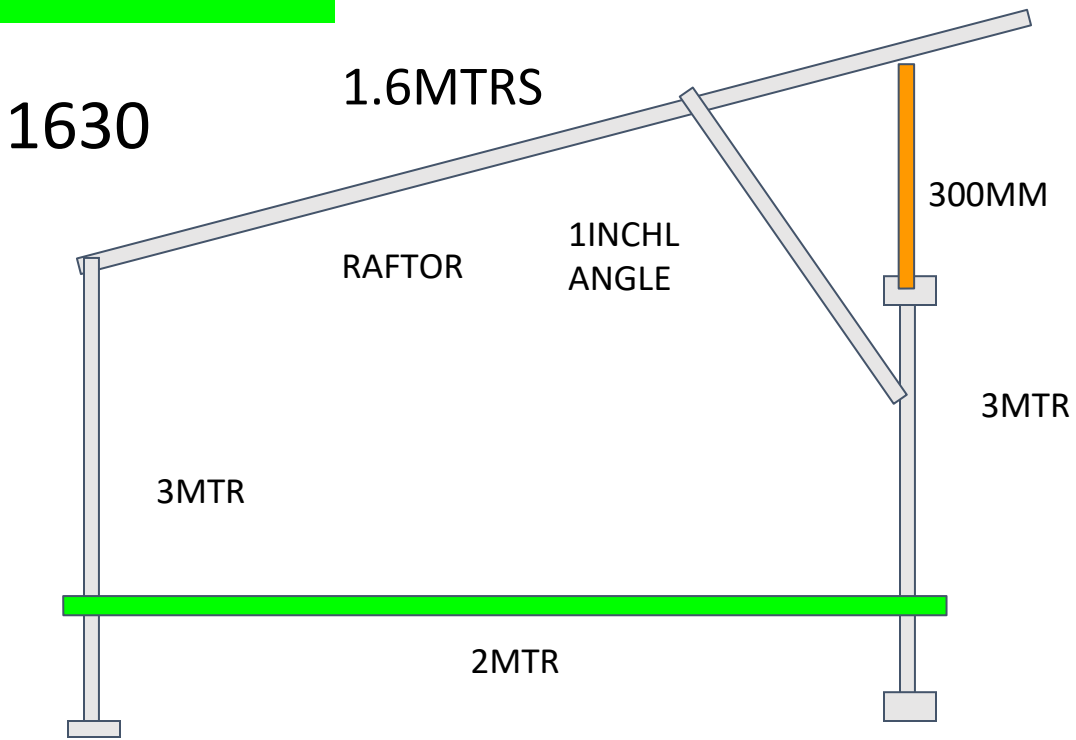



11Degree  
Elevation

RCCLEGSETS  
4.3MTRRAFTOR

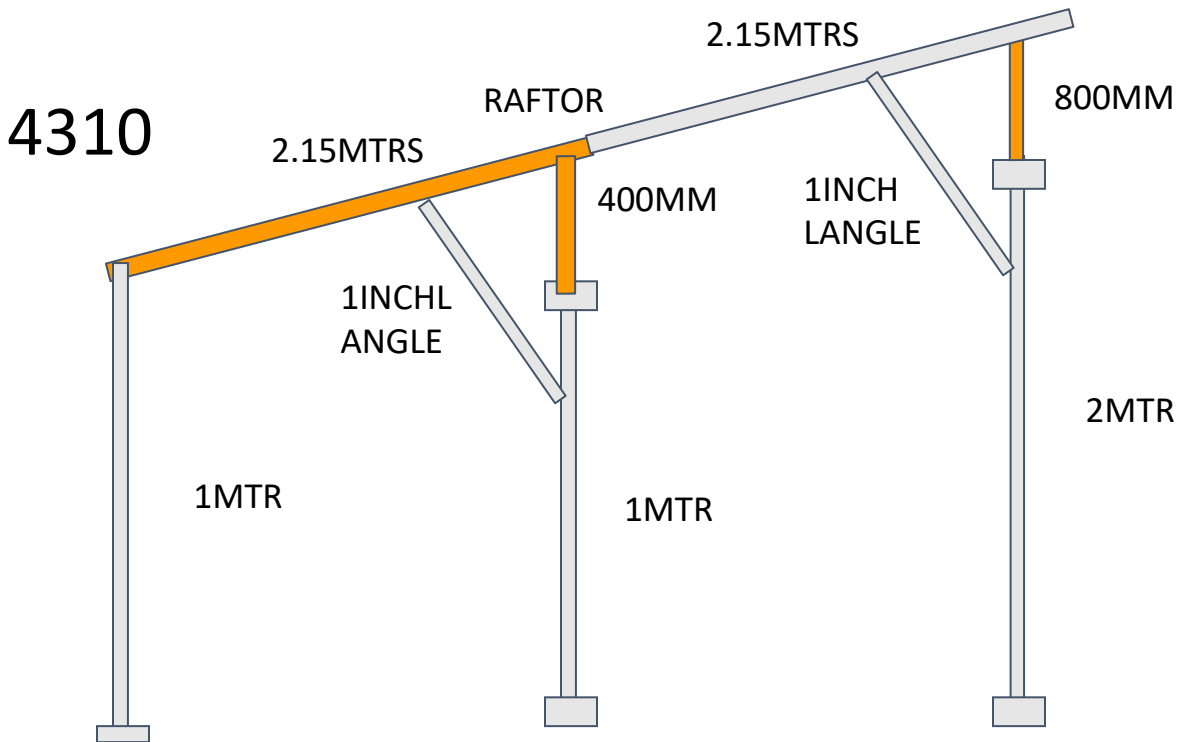
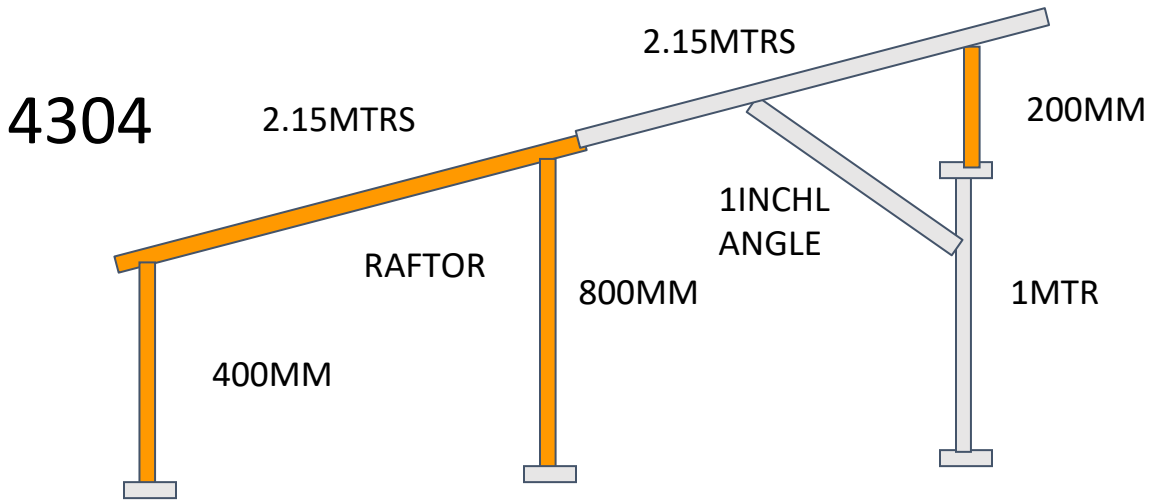
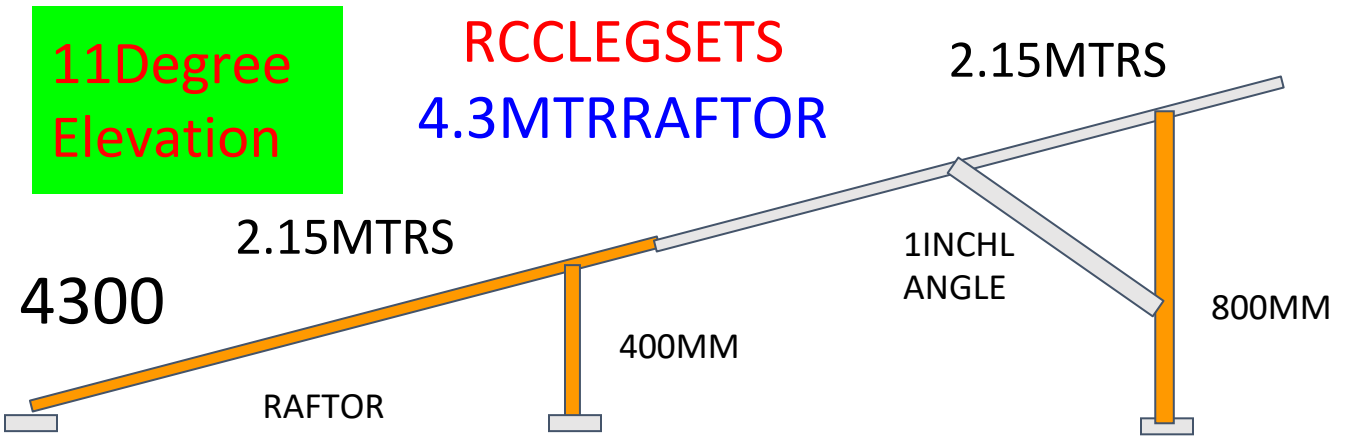

11Degree  
Elevation

# RCCLEGSETS 4.3MTRRAFTOR

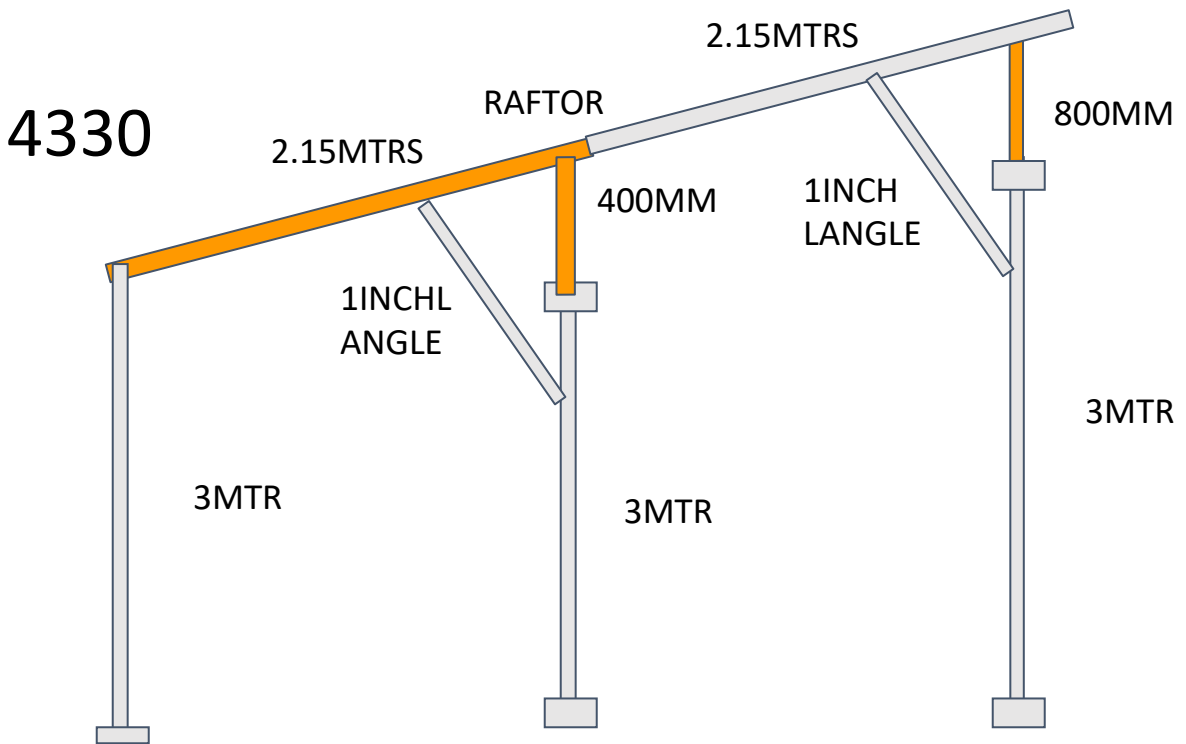
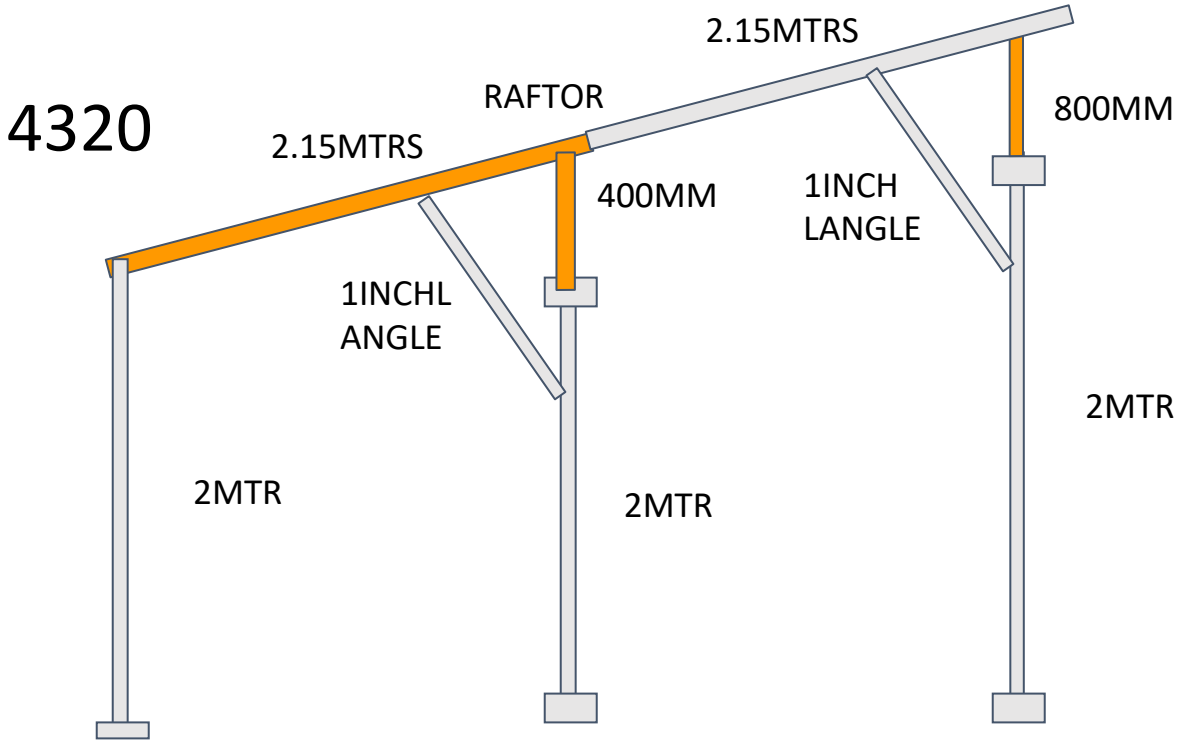

11Degree  
Elevation

RCCLEGSETS  
5.9MTRRAFTOR

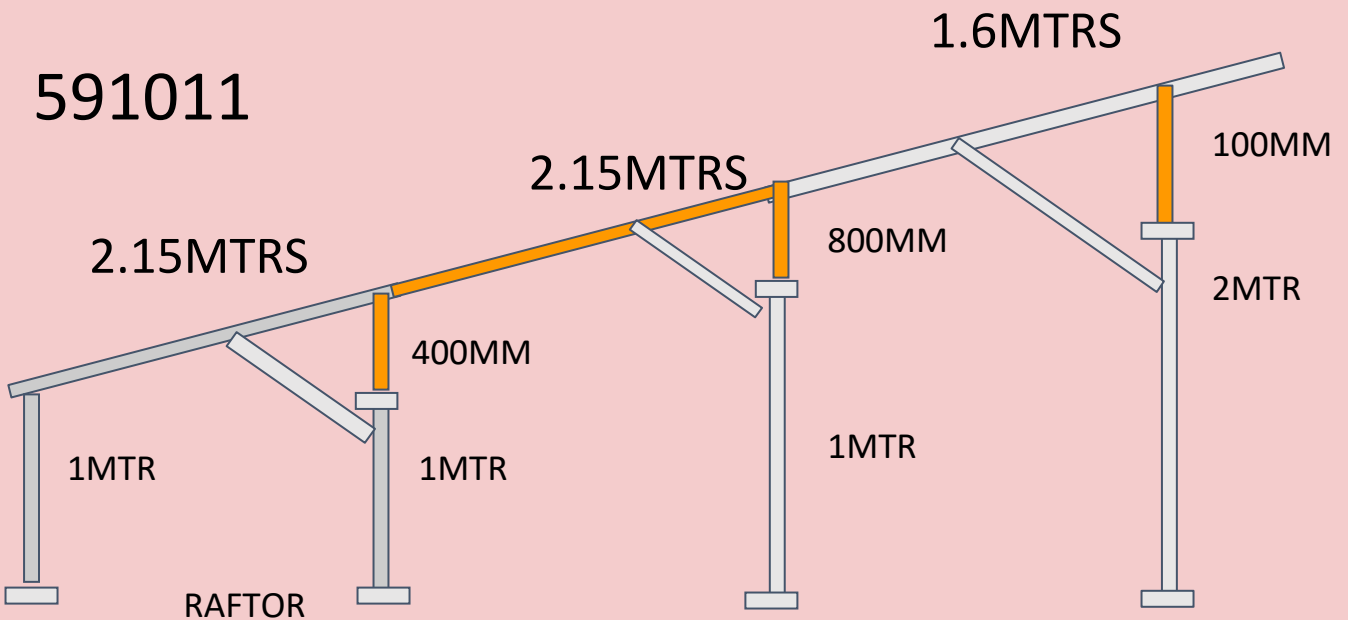
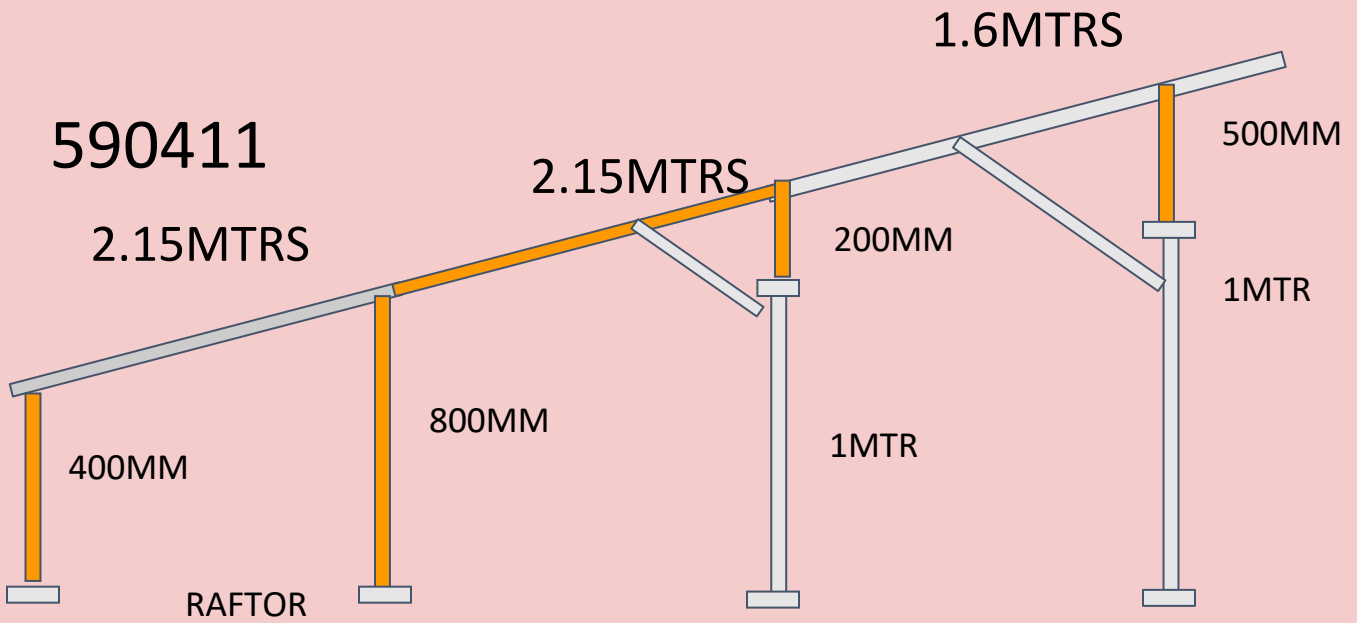
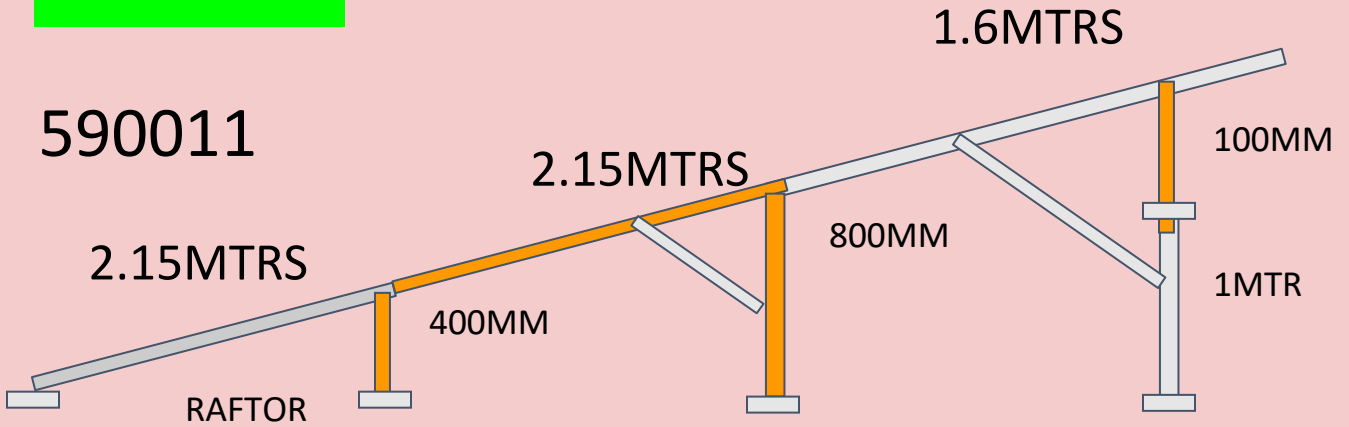

11Degree  
Elevation

RCCLEGSETS  
5.9MTRRAFTOR

592011

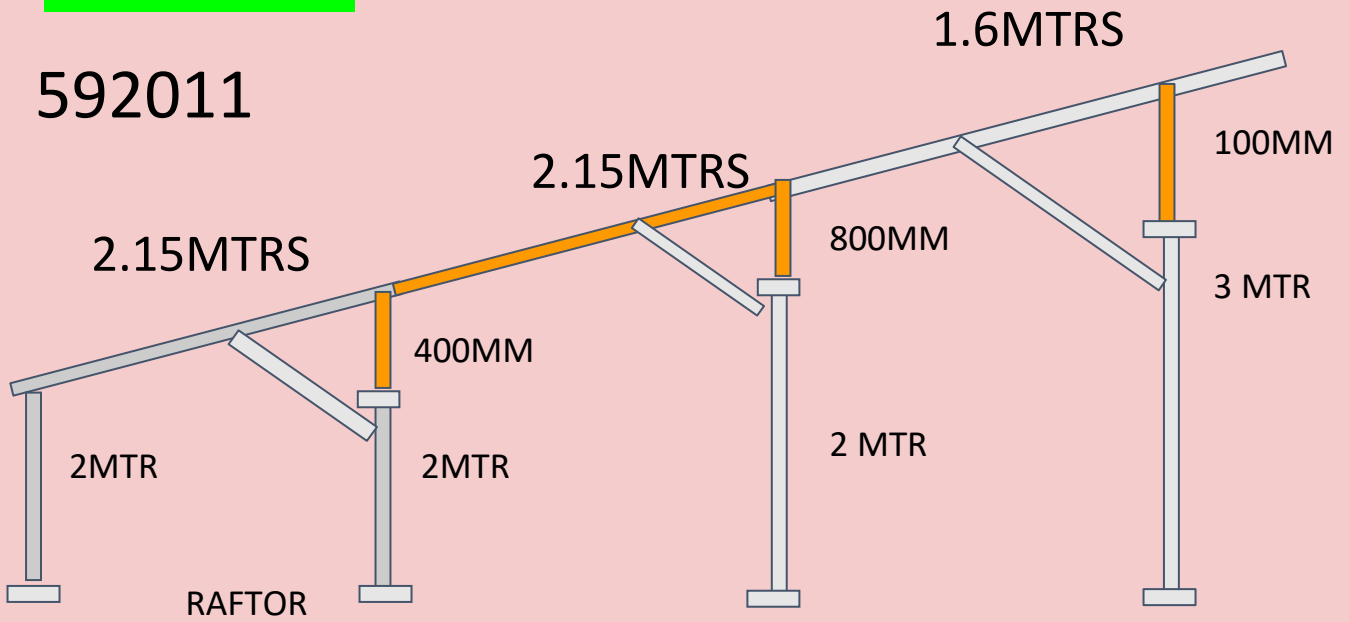

11Degree  
Elevation

RCCLEGSETS  
5.9MTRRAFTOR

593011

